

ANSI B16.47 Series B Class 75 Flanges

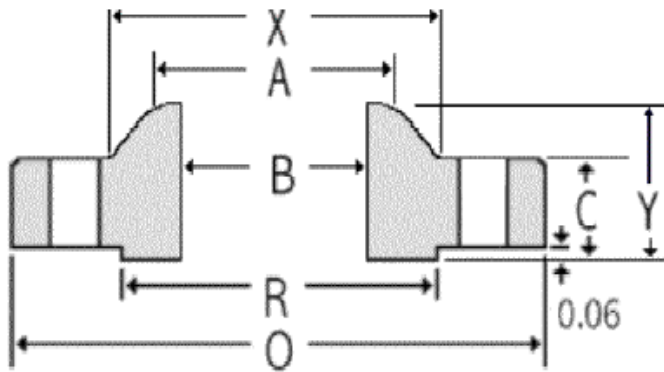

Weld Neck

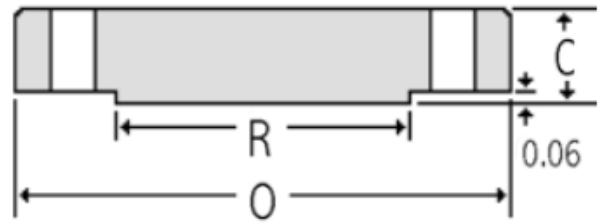

Blind

Nom. Pipe Size	Thickness					Drilling					Weight		
	OD	Weld Neck	Blind	OD RF	Dia at Base	Bore	LTH	Dia Bevel	Bolt Circle	Dia Holes	# Holes	Weld Neck	Blind
	O	C	C	R	X	B	Y	A					
26	30.00	1.31	1.31	27.75	26.62	To be specified by purchaser.	2.31	26.06	28.50	0.75	36.00	80	255
28	32.00	1.31	1.31	29.75	28.62		2.44	28.06	30.50	0.75	40.00	85	290
30	34.00	1.31	1.31	31.75	30.62		2.56	30.06	32.50	0.75	44.00	90	330
32	36.00	1.38	1.44	33.75	32.62		2.75	32.06	34.50	0.75	48.00	105	390
34	38.00	1.38	1.50	35.75	34.62		2.88	34.06	36.50	0.75	52.00	110	430
36	40.69	1.44	1.67	38.00	36.81		3.38	36.06	39.06	0.88	40.00	145	518
38	42.69	1.50	1.75	40.00	38.81		3.50	38.06	41.06	0.88	40.00	160	595
40	44.69	1.50	1.75	42.00	40.81		3.62	40.06	43.06	0.88	44.00	170	760
42	46.69	1.56	1.88	44.00	42.81		3.75	42.06	45.06	0.88	48.00	185	895
44	49.25	1.69	1.94	46.25	44.88		4.12	44.06	47.38	1.00	36.00	230	1,065
46	51.25	1.75	2.00	48.25	46.88		4.25	46.06	49.38	1.00	40.00	245	1,185
48	53.25	1.81	2.12	50.25	48.88		4.38	48.06	51.38	1.00	44.00	270	1,315
50	55.25	1.88	2.18	52.25	50.94		4.56	50.06	53.38	1.00	44.00	290	1,505
52	57.38	1.88	2.25	54.25	52.94		4.75	52.06	55.50	1.00	48.00	310	1,665
54	59.38	1.94	2.38	56.25	55.00		4.94	54.06	57.50	1.00	48.00	340	1,840
56	62.00	2.00	2.44	58.50	57.12		5.31	56.06	59.88	1.12	40.00	400	2,110
58	64.00	2.06	2.50	60.50	59.12		5.44	58.06	61.88	1.12	44.00	430	2,300
60	66.00	2.19	2.62	62.50	61.12		5.69	60.06	63.88	1.12	44.00	475	2,500

Dimensions in inches.

Note: Larger sizes as well as intermediate sizes can be furnished.

Tel: +919867815181

Email: sales@randhirmetal.com

Website: www.randhirmetal.com

ANSI B16.47 Series B Class 150 Flanges

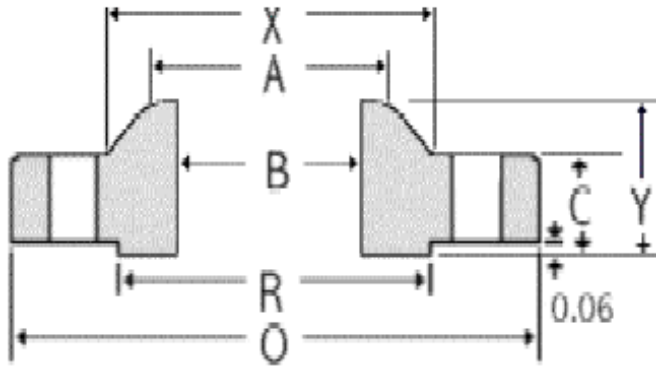

Weld Neck

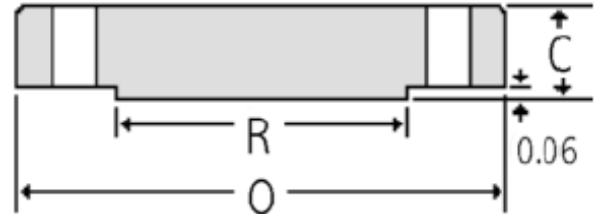

Blind

Dimensions in inches.

Note: Larger sizes as well as intermediate sizes can be furnished.



Nom. Pipe Size	Thickness					Bore B	LTH Y	Dia Bevel A	Drilling			Weight	
	OD	Weld Neck	Blind	OD RF	Dia at Base				Bolt Circle	Dia Holes	# Holes	Weld Neck	Blind
	O	C	C	R	X								
26	30.94	1.62	1.75	28.00	26.94	To be specified by purchaser.	3.50	26.06	29.31	0.88	36.00	120	373
28	32.94	1.75	1.88	30.00	28.94		3.75	28.06	31.31	0.88	40.00	140	454
30	34.94	1.75	2.00	32.00	31.00		3.94	30.06	33.31	0.88	44.00	150	543
32	37.06	1.81	2.12	34.00	33.06		4.25	32.06	35.44	0.88	48.00	170	648
34	39.56	1.94	2.25	36.25	35.12		4.34	34.06	37.69	1.00	40.00	210	783
36	41.62	2.06	2.31	38.25	37.19		4.62	36.06	39.75	1.00	44.00	240	890
38	44.25	2.12	2.50	40.25	39.25		4.88	38.12	42.12	1.12	40.00	290	1,089
40	46.25	2.19	2.62	42.50	41.31		5.06	40.12	44.12	1.12	44.00	310	1,247
42	48.25	2.31	2.69	44.50	43.38		5.25	42.12	46.12	1.12	48.00	345	1,393
44	50.25	2.38	2.81	46.50	45.38		5.38	44.12	48.12	1.12	52.00	370	1,579
46	52.81	2.44	2.94	48.62	47.44		5.69	46.12	50.56	1.25	40.00	435	1,824
48	54.81	2.56	3.06	50.75	49.50		5.88	48.12	52.56	1.25	44.00	480	2,045
50	56.81	2.69	3.18	52.75	51.50		6.06	50.12	54.56	1.25	48.00	520	2,284
52	58.81	2.75	3.31	54.75	53.56		6.19	52.12	56.56	1.25	52.00	550	2,547
54	61.00	2.81	3.44	56.75	55.62		6.38	54.12	58.75	1.25	56.00	620	2,848
56	63.00	2.88	3.56	58.75	57.69		6.56	56.12	60.75	1.25	60.00	650	3,144
58	65.94	2.94	3.68	60.75	59.69		6.88	58.12	63.44	1.38	48.00	780	3,560
60	67.94	3.00	3.81	63.00	61.81		7.06	60.12	65.44	1.38	52.00	850	3,913

Tel: +919867815181

Email: sales@randhirmetal.com

Website: www.randhirmetal.com

ANSI B16.47 Series B Class 300 Flanges

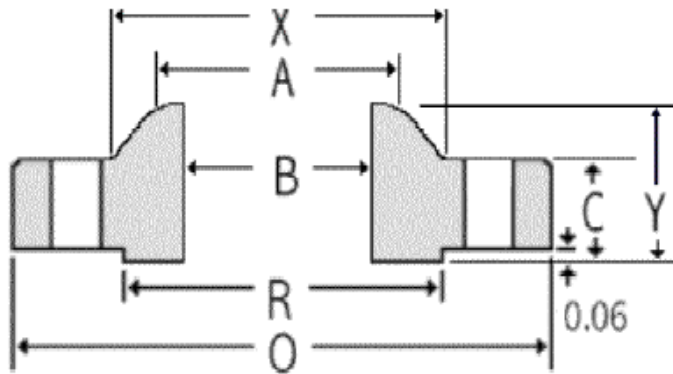

Weld Neck



Blind

Nom. Pipe Size	Thickness					Bore	Drilling					Weight	
	OD	Weld Neck	Blind	OD RF	Dia at Base		LTH	Dia Bevel	Bolt Circle	Dia Holes	# Holes	Weld Neck	Blind
	O	C	C	R	X		Y	A					
26	34.12	3.50	3.50	29.00	27.62	To be specified by purchaser.	5.69	26.19	31.62	1.38	32.00	400	907
28	36.25	3.50	3.50	31.00	29.75		5.88	28.19	33.75	1.38	36.00	450	1,023
30	39.00	3.69	3.69	33.25	32.00		6.22	30.25	36.25	1.50	36.00	550	1,249
32	41.50	4.06	4.06	35.50	34.00		6.62	32.25	38.50	1.62	32.00	685	1,556
34	43.62	4.06	4.06	37.50	36.12		6.81	34.25	40.62	1.62	36.00	750	1,719
36	46.12	4.06	4.06	39.75	38.00		7.12	36.25	42.88	1.75	32.00	840	1,921
38	48.12	4.38	4.38	41.75	40.00		7.56	38.25	44.88	1.75	36.00	915	2,257
40	50.12	4.56	4.56	43.88	42.00		7.81	40.25	46.88	1.75	40.00	990	2,549
42	52.50	4.69	4.69	46.00	44.00		8.06	42.31	49.00	1.88	36.00	1,135	2,876
44	54.50	5.00	5.00	48.00	46.19		8.44	44.31	51.00	1.88	40.00	1,235	3,304
46	57.50	5.06	5.12	50.00	48.38		8.75	46.31	53.75	2.00	36.00	1,470	3,766
48	59.50	5.06	5.31	52.25	50.31		8.81	48.31	55.75	2.00	40.00	1,575	4,183
50	61.50	5.44	5.50	54.25	52.38		9.25	50.31	57.75	2.00	44.00	1,710	4,629
52	63.50	5.62	5.68	56.25	54.44		9.56	52.31	59.75	2.00	48.00	1,840	5,096
54	65.88	5.38	5.88	58.25	56.50		9.44	54.31	62.12	2.00	48.00	1,980	5,678
56	69.50	6.06	6.18	60.50	58.81		10.56	56.31	65.00	2.38	36.00	2,595	6,642
58	71.94	6.06	6.38	62.75	60.94		10.81	58.31	67.44	2.38	40.00	2,770	7,347
60	73.94	5.94	6.56	65.00	62.94		10.69	60.31	69.44	2.38	40.00	2,870	7,980

Dimensions in inches.

Note: Larger sizes as well as intermediate sizes can be furnished.

Tel: +919867815181

Email: sales@randhirmetal.com

Website: www.randhirmetal.com

ANSI B16.47 Series B Class 400 Flanges

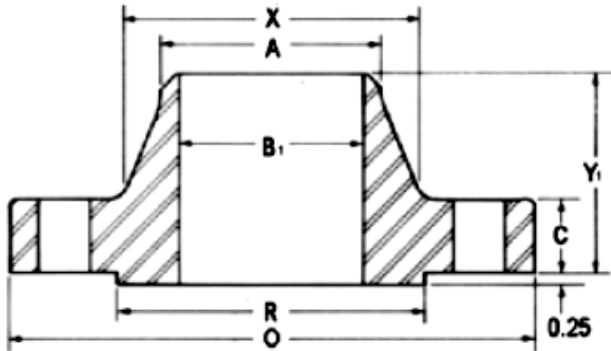

Weld Neck



Blind



Nom. Pipe Size	Thickness							Drilling			Weight	
	OD	Weld Neck	Blind	LTH	Dia at Base	Dia Bevel	OD RF	Bolt Circle	# Holes	Dia Holes	Weld Neck	Blind
	O	C	C	Y	X	A	R					
26	33.50	3.50	3.50	5.88	27.12	26.00	28.00	30.75	28.00	1.50	360	874
28	36.00	3.75	3.75	6.25	29.12	28.00	30.00	33.00	24.00	1.62	450	1,081
30	38.25	4.00	4.00	6.69	31.25	30.00	32.25	35.25	28.00	1.62	530	1,302
32	40.75	4.25	4.25	7.06	33.25	32.00	34.38	37.50	28.00	1.75	635	1,570
34	42.75	4.38	4.38	7.38	35.38	34.00	36.50	39.50	32.00	1.75	690	1,781
36	45.50	4.69	4.69	7.88	37.50	36.00	38.62	42.00	28.00	1.88	855	2,160
38	47.50	4.88	4.88	8.12	39.50	38.00	40.75	44.00	32.00	1.88	935	2,450
40	50.00	5.12	5.12	8.50	41.50	40.00	43.00	46.25	32.00	2.00	1,090	2,848
42	52.00	5.25	5.25	8.81	43.62	42.00	45.00	48.25	32.00	2.00	1,190	3,159
44	54.50	5.50	5.50	9.18	45.62	44.00	47.25	50.50	32.00	2.12	1,375	3,635
46	56.75	5.75	5.75	9.62	47.75	46.00	49.50	52.75	36.00	2.12	1,525	4,120
48	59.50	6.00	6.00	10.12	49.88	48.00	51.50	55.25	28.00	2.38	1,790	4,726
50	61.75	6.19	6.25	10.56	52.00	50.00	53.62	57.50	32.00	2.38	1,950	5,303
52	63.75	6.38	6.44	10.88	54.00	52.00	55.62	59.50	32.00	2.38	2,125	5,823
54	67.00	6.69	6.75	11.38	56.12	54.00	57.88	62.25	28.00	2.62	2,565	6,742
56	69.00	6.88	6.94	11.75	58.25	56.00	60.12	64.25	32.00	2.62	2,710	7,352
58	71.00	7.00	7.12	12.06	60.25	58.00	62.12	66.25	32.00	2.62	3,230	7,986
60	74.25	7.31	7.44	12.56	62.38	60.00	64.38	69.00	32.00	2.88	3,820	9,126

Dimensions in inches.

Note: Larger sizes as well as intermediate sizes can be furnished.

Tel: +919867815181

Email: sales@randhirmetal.com

Website: www.randhirmetal.com

ANSI B16.47 Series B Class 600 Flanges

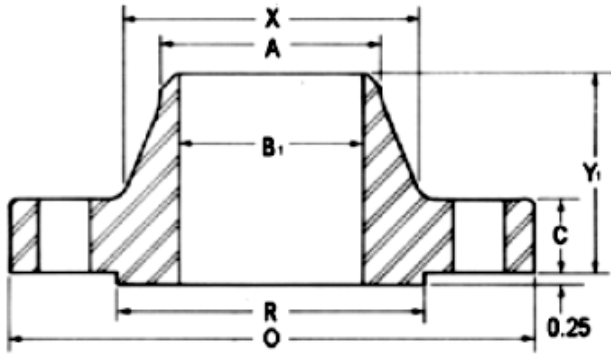

Weld Neck

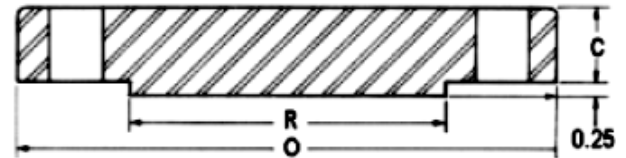

Blind



Nom. Pipe Size	Thickness							Drilling			Weight	
	OD	Weld Neck	Blind	LTH	Dia at Base	Dia Bevel	OD RF	Bolt Circle	# Holes	Dia Holes	Weld Neck	Blind
	O	C	C	Y	X	A	R					
26	35.00	4.38	4.38	7.12	27.50	26.00	28.62	31.75	28.00	1.75	550	1,194
28	37.50	4.56	4.56	7.50	29.62	28.00	30.88	34.00	28.00	1.88	650	1,427
30	40.25	4.94	5.00	8.06	31.75	30.00	33.12	36.50	28.00	2.00	810	1,802
32	42.75	5.12	5.31	8.50	33.88	32.00	35.25	38.75	28.00	2.12	950	2,159
34	45.75	5.56	5.68	9.19	36.00	34.00	37.50	41.50	24.00	2.38	1,205	2,645
36	47.75	5.75	5.94	9.56	38.12	36.00	39.75	43.50	28.00	2.38	1,340	3,013
38	50.00	6.00	6.12	10.00	40.25	38.00	41.50	45.75	28.00	2.38	1,470	3,404
40	52.00	6.25	6.38	10.38	42.25	40.00	43.75	47.75	32.00	2.38	1,630	3,838
42	55.25	6.62	6.75	11.00	44.38	42.00	46.00	50.50	28.00	2.62	2,030	4,585
44	57.25	6.81	7.00	11.38	46.50	44.00	48.25	52.50	32.00	2.62	2,160	5,105
46	59.50	7.06	7.31	11.81	48.62	46.00	50.25	54.75	32.00	2.62	2,410	5,758
48	62.75	7.44	7.69	12.44	50.75	48.00	52.50	57.50	32.00	2.88	2,855	6,737
50	65.75	7.75	8.00	12.94	52.88	50.00	54.50	60.00	28.00	3.12	3,330	7,695
52	67.75	8.00	8.25	13.25	54.88	52.00	56.50	62.00	32.00	3.12	3,560	8,426
54	70.00	8.25	8.56	13.75	57.00	54.00	58.75	64.25	32.00	3.12	3,920	9,333
56	73.00	8.56	8.88	14.25	59.12	56.00	60.75	66.75	32.00	3.38	4,280	10,529
58	75.00	8.75	9.12	14.56	61.12	58.00	63.00	68.75	32.00	3.38	4,640	11,414
60	78.50	9.19	9.56	15.31	63.38	60.00	65.25	71.75	28.00	3.62	5,000	13,108

Dimensions in inches.

Note: Larger sizes as well as intermediate sizes can be furnished.

Tel: +919867815181

Email: sales@randhirmetal.com

Website: www.randhirmetal.com

ANSI B16.47 Series B Class 900 Flanges

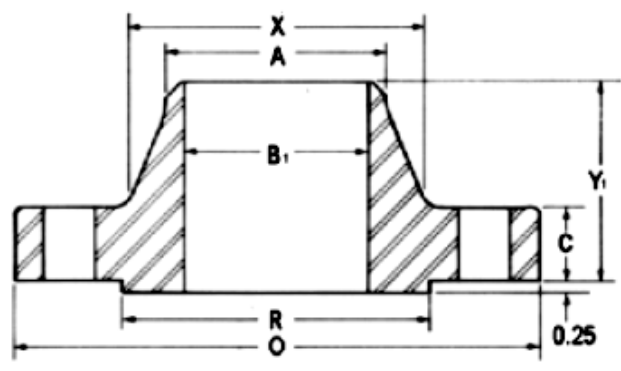

Weld Neck

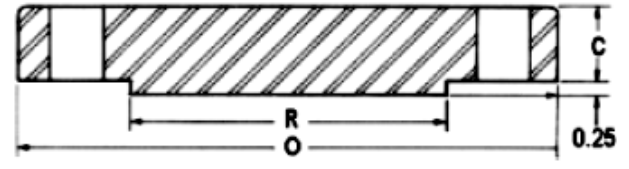

Blind

Nom. Pipe Size	Thickness							Drilling			Weight	
	OD	Weld Neck	Blind	LTH	Dia at Base	Dia Bevel	OD RF	Bolt Circle	# Holes	Dia Holes	Weld Neck	Blind
	O	C	C	Y	X	A	R					
26	40.25	5.31	6.06	10.19	29.25	26.00	30.00	35.50	20.00	2.62	1,050	2,184
28	43.50	5.81	6.56	10.88	31.38	28.00	32.25	38.25	20.00	2.88	1,520	2,762
30	46.50	6.12	6.93	11.38	33.50	30.00	34.50	40.75	20.00	3.12	1,820	3,334
32	48.75	6.31	7.31	11.94	35.75	32.00	36.50	43.00	20.00	3.12	2,065	3,865
34	51.75	6.75	7.68	12.56	37.88	34.00	39.00	45.50	20.00	3.38	2,450	4,576
36	53.00	6.81	7.94	12.81	40.00	36.00	40.50	47.25	24.00	3.12	2,520	4,963
38	57.50	7.50	8.50	13.88	42.25	38.00	43.25	50.75	20.00	3.62	3,385	6,253
40	59.50	7.75	8.81	14.31	44.38	40.00	45.75	52.75	24.00	3.62	3,620	6,940
42	61.50	8.12	9.12	14.62	46.31	42.00	47.75	54.75	24.00	3.62	3,960	7,675
44	64.88	8.44	9.56	15.38	48.62	44.00	50.00	57.62	24.00	3.88	4,300	8,954
46	68.25	8.88	10.06	16.18	50.88	46.00	52.50	60.50	24.00	4.12	4,640	10,426
48	70.25	9.19	10.38	16.50	52.88	48.00	54.50	62.50	24.00	4.12	4,980	11,398

Dimensions in inches.

Note: Larger sizes as well as intermediate sizes can be furnished.