



- ▲ Flat Flange For Welding
- ▲ Blind Flange
 - ▲ Threaded Flange With Neck
 - ▲ Welding Neck Flange
 - ▲ Lapped Joint Flange
 - ▲ Loose Flange And Ring
 - ▲ Loose Flange And Ring With Neck
- ▲ Long Neck Welding Flange
- ▲ Hubbed Slip-on Flange

DIN Flanges Summary Chart

Flange Type	Pressure Rating (PN)											
	2.5	6	10	16	25	40	64	100	160	250	320	400
	Flange Code (DIN)											
Blind flange		2527	2527	2527	2527	2527	2527	2527				
Flat flange for welding (slip on)		2573	2576	2502 2543	2503 2544	2503 2545						
Welding neck flange	2630	2631	2632	2633	2634	2635	2636	2637	2638	2628	2629	2627
Lapped (lapped joint) flange, Plain collar		2641	2642		2655	2656						
Loose flange and ring for welding		2652	2653									
Loose flange and ring with neck for welding			2673									
Threaded flange with neck		2565		2566	2567	2567	2568	2569				
Long neck welding flange			28115		28115							
Hubbed slip-on Flange for welding			86029	86030								

DIN 2502 Flat Flange For Welding (Slip On) PN16

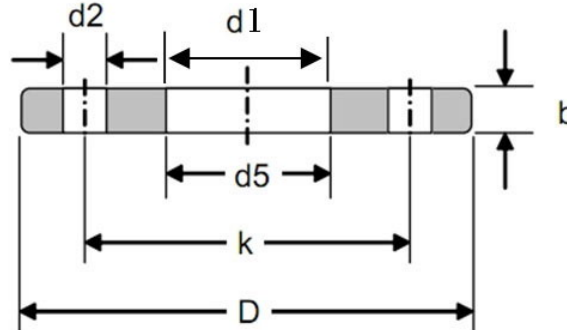

DN	ISO	DIN (d1)	d5	D	b	k	No. of Holes	d2	KG
10	-	14.0	14.5	90	16	60	4	14	0.61
	17.2	-	17.7	90	16	60	4	14	0.60
15	-	20.0	21.0	95	16	65	4	14	0.67
	21.3	-	22.0	95	16	65	4	14	0.67
20	-	25.0	26.0	105	18	75	4	14	0.94
	26.9	-	27.6	105	18	75	4	14	0.94
25	-	30.0	31.0	115	18	85	4	14	1.13
	33.7	-	34.4	115	18	85	4	14	1.11
32	-	38.0	39.0	140	18	100	4	18	1.66
	42.4	-	43.1	140	18	100	4	18	1.62
40	-	44.5	45.5	150	18	110	4	18	1.89
	48.3	-	49.0	150	18	110	4	18	1.85
50	-	57.0	58.1	165	18	125	4	18	2.50
	60.3	-	61.1	165	18	125	4	18	2.46
65	76.1	-	77.1	185	22	145	8	18	2.99
80	88.9	-	90.3	200	24	160	8	18	3.61
100	-	108.0	109.6	220	20	180	8	18	4.17
	114.3	-	115.9	220	20	180	8	18	3.99
125	-	133.0	134.8	250	22	210	8	18	5.66
	139.7	-	141.6	250	22	210	8	18	5.41
150	-	159.0	161.1	285	22	240	8	22	6.97
	168.2	-	170.5	285	22	240	8	22	6.55
175	193.7	-	196.10	315	24	270	8	22	8.42
200	219.1	-	221.8	340	24	295	12	22	8.97
250	-	267.0	270.2	405	26	355	12	26	13.29
	273.0	-	276.2	405	26	355	12	26	12.76
300	323.9	-	327.6	460	28	410	12	26	16.60
350	355.6	-	359.7	520	30	470	16	26	24.08
	-	368	372.2	520	30	470	16	26	22.39
400	406.4	-	411.0	580	32	525	16	30	30.20
	-	419	423.7	580	32	525	16	30	28.11
450	457.0	-	462.3	640	38	585	20	30	41.67
500	508.0	-	513.6	715	38	650	20	33	52.87
600	610.0	-	616.5	840	42	770	20	36	77.58
700	711.0	-	716.0	910	44	840	24	36	77.13
800	813.0	-	818.0	1025	50	950	24	39	106.35
900	914.0	-	920.0	1125	54	1050	28	39	125.39
1000	1016.0	-	1022.0	1255	60	1170	28	42	177.99

Dimensions in millimeter (mm).
For DN10-DN80 use PN40.

DIN 2503 Flat Flange For Welding (Slip On) PN25

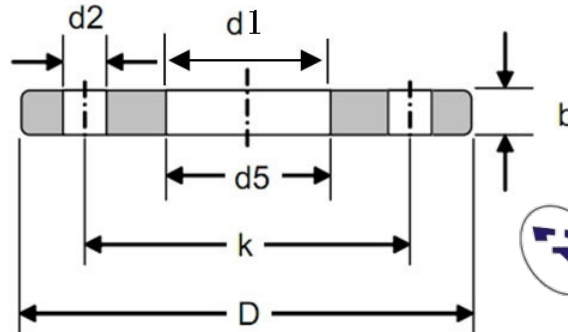

DN	Pipe OD		d5	D	b	k	No. of Holes	d2	KG
	ISO	DIN							
10	-	14.0	14.5	90	16	60	4	14	0.61
	17.2	-	17.7	90	16	60	4	14	0.60
15	-	20.0	21.0	95	16	65	4	14	0.67
	21.3	-	22.0	95	16	65	4	14	0.67
20	-	25.0	26.0	105	18	75	4	14	0.94
	26.9	-	27.6	105	18	75	4	14	0.94
25	-	30.0	31.0	115	18	85	4	14	1.13
	33.7	-	34.4	115	18	85	4	14	1.11
32	-	38.0	39.0	140	18	100	4	18	1.66
	42.4	-	43.1	140	18	100	4	18	1.62
40	-	44.5	45.5	150	18	110	4	18	1.89
	48.3	-	49.0	150	18	110	4	18	1.85
50	-	57.0	58.1	165	18	125	4	18	2.50
	60.3	-	61.1	165	18	125	4	18	2.46
65	76.1	-	77.1	185	22	145	8	18	2.99
80	88.9	-	90.3	200	24	160	8	18	3.61
100	-	108.0	109.6	235	24	190	8	22	5.82
	114.3	-	115.9	235	24	190	8	22	5.61
125	-	133.0	134.8	270	26	220	8	26	7.91
	139.7	-	141.6	270	26	220	8	26	7.83
150	-	159.0	161.1	300	28	250	8	26	10.12
	168.2	-	170.5	300	28	250	8	26	9.58
175	193.70	-	196.10	330	28	280	12	26	14.45
200	219.1	-	221.8	360	30	310	12	26	13.60
250	-	267.0	270.2	425	32	370	12	30	19.40
	273.0	-	276.2	425	32	370	12	30	18.45
300	323.9	-	327.6	485	34	430	16	30	23.79
350	355.6	-	359.7	555	38	490	16	33	33.77
	-	368	372.2	555	38	490	16	33	35.63
400	406.4	-	411.0	620	40	550	16	36	48.03
	-	419	423.7	620	40	550	16	36	45.41
500	508.0	-	513.6	730	44	660	20	36	65.97
600	610.0	-	616.5	845	50	770	20	39	93.57
700	711.0	-	716.0	960	52	875	24	42	117.53
800	813.0	-	818.0	1085	56	990	24	48	156.34
900	914.0	-	920.0	1185	62	1090	28	48	188.57
1000	1016.0	-	1022.0	1320	68	1210	28	58	255.79

Dimensions in millimeter (mm).
 For DN10-DN150 use PN40.

DIN 2503 Flat Flange For Welding (Slip On) PN40

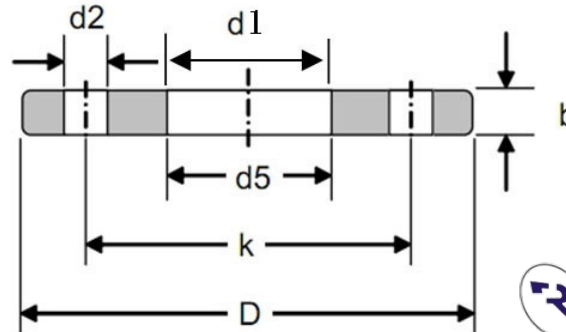

DN	Pipe OD		d5	D	b	k	No. of Holes	d2	KG
	ISO	DIN							
10	-	14.0	14.5	90	16	60	4	14	0.61
	17.2	-	17.7	90	16	60	4	14	0.60
15	-	20.0	21.0	95	16	65	4	14	0.67
	21.3	-	22.0	95	16	65	4	14	0.67
20	-	25.0	26.0	105	18	75	4	14	0.94
	26.9	-	27.6	105	18	75	4	14	0.94
25	-	30.0	31.0	115	18	85	4	14	1.13
	33.7	-	34.4	115	18	85	4	14	1.11
32	-	38.0	39.0	140	18	100	4	18	1.66
	42.4	-	43.1	140	18	100	4	18	1.62
40	-	44.5	45.5	150	18	110	4	18	1.89
	48.3	-	49.0	150	18	110	4	18	1.85
50	-	57.0	58.1	165	18	125	4	18	2.50
	60.3	-	61.1	165	18	125	4	18	2.46
65	76.1	-	77.1	185	22	145	8	18	2.99
80	88.9	-	90.3	200	24	160	8	18	3.61
100	-	108.0	109.6	235	24	190	8	22	5.82
	114.3	-	115.9	235	24	190	8	22	5.61
125	-	133.0	134.8	270	26	220	8	26	7.91
	139.7	-	141.6	270	26	220	8	26	7.83
150	-	159.0	161.1	300	28	250	8	26	10.12
	168.2	-	170.5	300	28	250	8	26	9.58
175	193.7	-	196.1	350	2	295	12	30	14.45
200	219.1	-	221.8	375	34	320	12	30	16.90
250	-	267.0	270.2	450	38	385	12	33	27.28
	273.0	-	276.2	450	38	385	12	33	26.51
300	323.9	-	327.6	515	42	450	16	33	36.38
350	355.6	-	359.7	580	46	510	16	36	52.83
	-	368.0	372.2	580	46	510	16	36	50.24
400	406.4	-	411.0	660	50	585	16	39	74.71
	-	419	423.7	660	50	585	16	39	71.44
500	508.0	-	513.6	755	52	670	20	42	86.87
600	610.0	-	616.5	890	54	795	20	48	121.84
700	711.0	-	716.0	995	58	900	24	48	150.93
800	813.0	-	818.0	1140	64	1030	24	58	219.08
900	914.0	-	920.0	1250	70	1140	28	58	271.16
1000	1016.0	-	1022.0	1360	78	1250	28	58	344.95

Dimensions in millimeter (mm).

Tel: +919867815181

Email: sales@randhirmetal.com

Website: www.randhirmetal.com

DIN 2527 Blind Flange

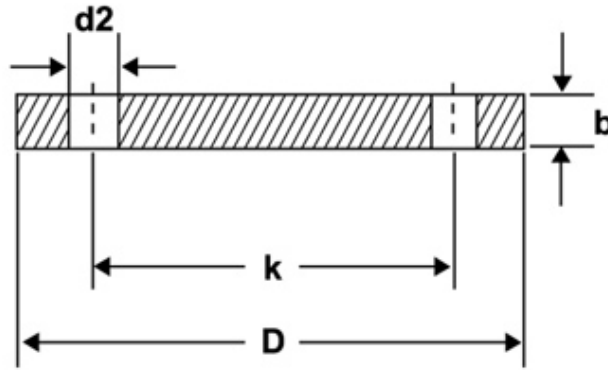

DIN	PN6						PN10				
	No. of holes	D	b	k	d2	KG	D	b	k	d2	KG
10	4	75	12	50	11	0.38	90	14	60	14	0.63
15	4	80	12	55	11	0.44	95	14	65	14	0.71
20	4	90	14	65	11	0.66	105	16	75	14	1.01
25	4	100	14	75	11	0.82	115	16	85	14	1.23
32	4	120	14	90	14	1.18	140	16	100	18	1.81
40	4	130	14	100	14	1.39	150	16	110	18	2.09
50	4	140	14	110	14	1.62	165	18	125	18	2.88
65	4	160	14	130	14	2.14	185	18	145	18	3.65
80	4	190	16	150	48	3.43	200	20	160	18	4.61
100	4	210	16	170	18	4.22	220	20	180	18	5.65
125	8	240	18	200	18	6.1	250	22	210	18	8.13
150	8	265	18	225	18	7.51	285	22	240	22	10.49
175	8	295	20	255	18	10.41	315	24	270	22	14.11
200	8	320	20	280	18	12.31	340	24	295	22	16.53
250	12	375	22	335	18	18.55	395	26	350	22	24.08
300	12	440	22	395	22	25.47	445	26	400	22	30.81
350	12	490	22	445	22	31.78	505	26	460	22	39.64
400	16	540	22	495	22	38.5	565	26	515	26	49.44
500	20	645	24	600	22	60.13	670	28	620	26	75.16
600	20	755	28	705	26	96.07	780	30	725	30	109.2
700	24	860	30	810	26	133.8	895	32	840	30	153.77
800	24	975	32	920	30	183.29	1015	36	950	33	222.86
900	24	1075	36	1020	30	251.7	1115	40	1050	33	299.08
1000	28	1175	42	1120	30	350.98	1230	46	1160	36	418.78

Dimensions in millimeter (mm).

Tel: +919867815181

Email: sales@randhirmetal.com

Website: www.randhirmetal.com

DIN 2527 Blind Flange

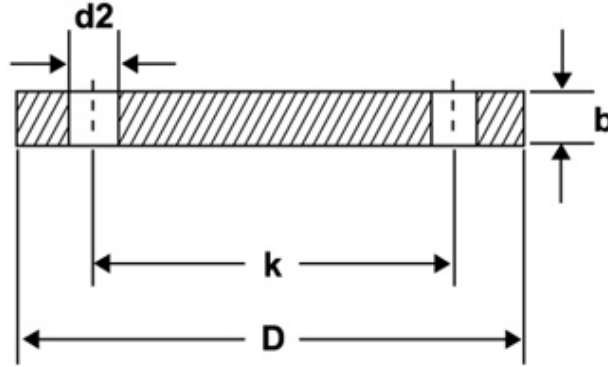

PN16							PN25				
DIN	No. of holes	D	b	k	d2	KG	D	b	k	d2	KG
10	4	90	14	60	14	0.63	90	16	60	14	0.72
15	4	95	14	65	14	0.71	95	16	65	14	0.81
20	4	105	16	75	14	1.01	105	18	75	14	1.14
25	4	115	16	85	14	1.23	115	18	85	14	1.38
32	4	140	16	100	18	1.81	140	18	100	18	2.03
40	4	150	16	110	18	2.09	150	18	110	18	2.35
50	4	165	18	125	18	2.88	165	20	125	18	3.2
65	4	185	18	145	18	3.65	185	22	145	18	4.29
80	8	200	20	160	18	4.61	200	24	160	18	5.54
100	8	220	20	180	18	5.65	235	24	190	22	7.6
125	8	250	22	210	18	8.13	270	26	220	26	10.82
150	8	285	22	240	22	10.49	300	28	250	26	14.6
175	8	315	24	270	22	14.11	330	28	280	26	17.4
200	12	340	24	295	22	16.26	360	30	310	26	22.47
250	12	405	26	355	26	24.99	425	32	370	30	33.51
300	12	460	28	410	26	35.13	485	34	430	30	46.29
350	16	520	30	470	26	48.01	555	38	490	33	68.08
400	16	580	32	525	30	83.53	620	40	550	36	89.59
500	20	715	36	650	33	108.63	730	45	660	36	140.66
600	20	780	38	770	36	136.47	845	48	770	39	202.3
700	24	895	40	840	36	189.87	960	50	875	42	271.05
800	24	1015	44	950	39	269.57	1085	54	990	48	373.52
900	28	1115	48	1050	39	355.31	1185	58	1090	48	479.07
1000	28	1230	52	1170	42	469.2	1320	62	1210	56	632.47

Dimensions in millimeter (mm).

DIN 2527 Blind Flange

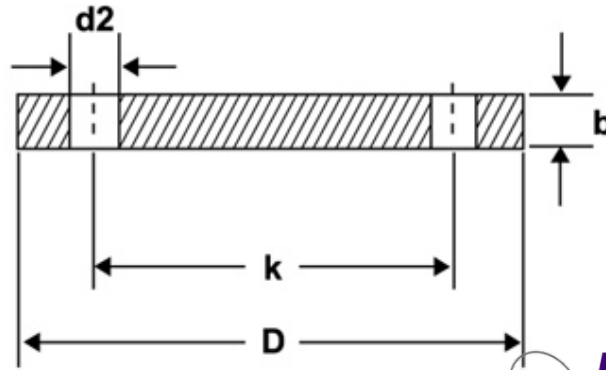

PN40							PN64				
DIN	No. of holes	D	b	k	d2	KG	D	b	k	d2	KG
10	4	90	16	60	14	0.72	100	20	70	14	1.04
15	4	95	16	65	14	0.81	105	20	75	14	2.98
20	4	105	18	75	14	1.14	130	22	90	18	2.19
25	4	115	18	85	14	1.38	140	24	100	18	2.65
32	4	140	18	100	18	2.03	155	24	110	22	3.26
40	4	150	18	110	18	2.35	170	26	125	22	4.18
50	4	165	20	125	18	3.2	180	26	135	22	4.67
65	8	185	22	145	18	4.29	205	26	160	22	5.94
80	8	200	24	160	18	5.54	215	28	170	22	7.18
100	8	235	24	190	22	7.6	250	30	200	26	10.10
125	8	270	26	220	26	10.82	295	34	240	30	16.10
150	8	300	28	250	26	14.6	345	36	280	33	23.50
175	12	350	32	295	30	22.04	375	40	310	33	30.80
200	12	375	34	320	30	27.21	415	42	345	36	39.70
250	12	450	38	385	33	44.38	470	46	400	36	56.70
300	16	515	42	450	33	64.17	530	52	460	36	57.40
350	16	580	46	510	36	89.52	600	56	525	39	114
400	16	660	50	585	39	126.76	670	60	585	42	152
500	20	755	56	670	42	184.63	-	-	-	-	-
600	20	890	62	795	48	285.17	-	-	-	-	-
700	24	995	64	900	48	368.83	-	-	-	-	-
800	24	1140	70	1030	56	528.39	-	-	-	-	-
900	28	1250	76	1140	56	690.99	-	-	-	-	-
1000	28	1360	84	1250	56	912.42	-	-	-	-	-

Dimensions in millimeter (mm).

DIN 2527 Blind Flange

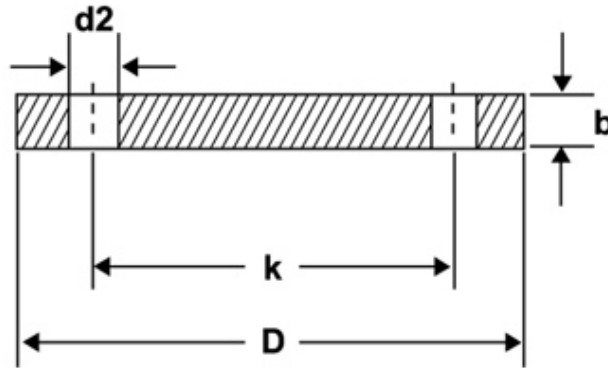

PN100						
DN	D	b	k	No. of holes	d2	KG
10	100	20	70	4	14	1.04
15	105	20	75	4	14	1.16
25	140	24	100	4	18	2.54
32	155	24	110	4	22	3.07
40	170	26	125	4	22	3.97
50	195	28	145	4	26	5.64
65	220	30	170	8	26	7.43
80	230	32	180	8	26	8.84
100	265	36	210	8	30	13.31
125	315	40	250	8	33	21.3
150	355	44	290	12	33	29.43
175	385	48	320	12	33	38.75
200	430	52	360	12	36	52.66
250	505	60	430	12	39	85.41
300	585	68	500	16	42	128.05
350	655	74	560	16	48	174.53

Dimensions in millimeter (mm).

DIN 2543 Flat Flange For Welding (Slip On) PN16

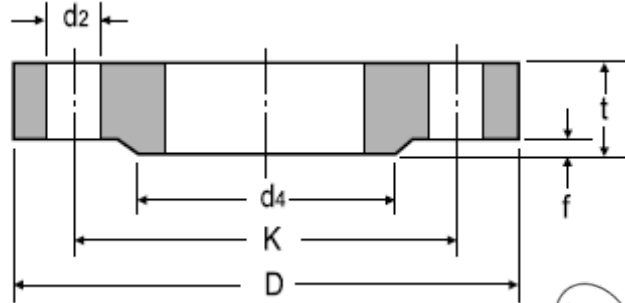

DN	Pipe OD		d4	D	t	f	K ϕ	No. of Holes	d2	KG
	ISO	DIN								
10	17.2	14	40	90	-	2	60	4	14	0.63
15	21.3	20	45	95	14	2	65	4	14	0.72
20	26.9	25	58	105	16	2	75	4	14	1.01
25	33.7	30	68	115	16	2	85	4	14	1.23
32	42.4	38	78	140	16	2	100	4	18	1.80
40	48.3	44.5	88	150	16	3	110	4	18	2.09
50	60.3	57	102	165	18	3	125	4	18	2.88
65	76.1	-	122	185	18	3	145	4	18	3.66
80	88.9	-	138	200	20	3	160	8	18	4.77
100	114.3	108	158	220	20	3	180	8	18	5.65
125	139.7	133	188	250	22	3	210	8	18	8.42
150	168.3	159	212	285	22	3	240	8	23	10.40
200	219.1	216	268	340	24	3	295	12	23	16.10
250	273	267	320	405	26	3	355	12	27	24.90
300	323.9	318	378	460	28	4	410	12	27	35.10
350	355.6	368	438	520	30	4	470	16	27	47.80
400	406.4	419	490	580	32	4	525	16	30	63.50
500	508	521	610	715	36	4	650	20	33	102.00
600	609.6	622	725	840	40	5	770	20	36	-
700	711.2	720	795	910	-	5	840	24	36	-
800	812.8	820	900	1025	-	5	950	24	39	-
900	914.4	920	1000	1125	-	5	1050	28	39	-
1000	1016	1020	1115	1255	-	5	1170	28	42	-

Dimensions in millimeter (mm).

DIN 2544 Flat Flange For Welding (Slip On) PN25

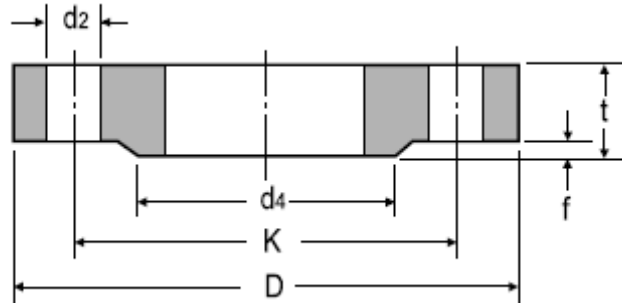

DN	Pipe OD		d4	D	t	f	K φ	No. of Holes	d2	KG
	ISO	DIN								
10	17.2	14	40	90	-	2	60	4	14	0.72
15	21.3	20	45	95	16	2	65	4	14	0.81
20	26.9	25	58	105	18	2	75	4	14	1.24
25	33.7	30	68	115	18	2	85	4	14	1.38
32	42.4	38	78	140	18	2	100	4	18	2.03
40	48.3	44.5	88	150	18	3	110	4	18	2.35
50	60.3	57	102	165	20	3	125	4	18	3.20
65	76.1	-	122	185	22	3	145	4	18	4.29
80	88.9	-	138	200	24	3	160	8	18	5.88
100	114.3	108	162	235	24	3	190	8	23	7.54
125	139.7	133	188	270	26	3	220	8	27	10.80
150	168.3	159	218	300	28	3	250	8	27	14.50
200	219.1	216	278	360	30	3	310	12	27	22.30
250	273	267	335	425	32	3	370	12	30	33.50
300	323.9	318	395	485	34	4	430	16	30	46.30
350	355.6	368	450	555	38	4	490	16	33	68.00
400	406.4	419	505	620	40	4	550	16	36	89.70
500	508	521	615	730	44	4	660	20	36	138.00
600	609.6	622	720	845	-	5	770	20	39	-
700	711.2	720	820	960	-	5	870	24	42	-
800	812.8	820	930	1085	-	5	990	24	48	-
900	914.4	920	1030	1185	-	5	1090	28	48	-
1000	1016	1020	1140	1320	-	5	1210	28	56	-

Dimensions in millimeter (mm).

Tel: +919867815181

Email: sales@randhirmetal.com

Website: www.randhirmetal.com

DIN 2545 Flat Flange For Welding (Slip On) PN40

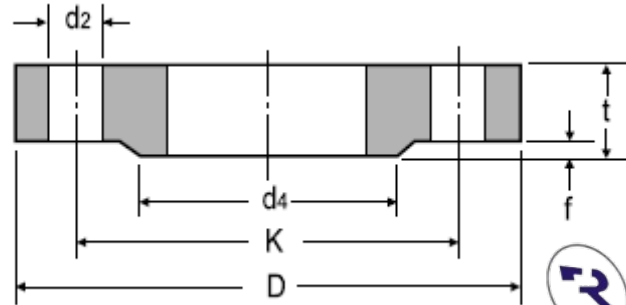

DN	Pipe OD		d4	D	t	f	K φ	No. of Holes	d2	KG
	ISO	DIN								
10	17.2	14	40	90	-	2	60	4	14	0.72
15	21.3	20	45	95	16	2	65	4	14	0.81
20	26.9	25	58	105	18	2	75	4	14	1.24
25	33.7	30	68	115	18	2	85	4	14	1.38
32	42.4	38	78	140	18	2	100	4	18	2.03
40	48.3	44.5	88	150	18	3	110	4	18	2.35
50	60.3	57	102	165	20	3	125	4	18	3.20
65	76.1	-	122	185	22	3	145	4	18	4.29
80	88.9	-	138	200	24	3	160	8	18	5.88
100	114.3	108	162	235	24	3	190	8	23	7.54
125	139.7	133	188	270	26	3	220	8	27	10.80
150	168.3	159	218	300	28	3	250	8	27	14.50
175	193.7	191	260	350	32	3	295	12	30	22.10
200	219.1	216	285	375	34	3	320	12	30	27.20
250	273	267	345	450	38	3	385	12	33	43.80
300	323.9	318	410	515	42	4	450	16	33	63.30
350	355.6	368	465	580	46	4	510	16	36	89.50
400	406.4	419	535	660	50	4	585	16	39	127.00
500	508	521	615	755	52	4	670	20	42	172.00

Dimensions in millimeter (mm).

DIN 2558 Oval Plain Threaded Flange PN6

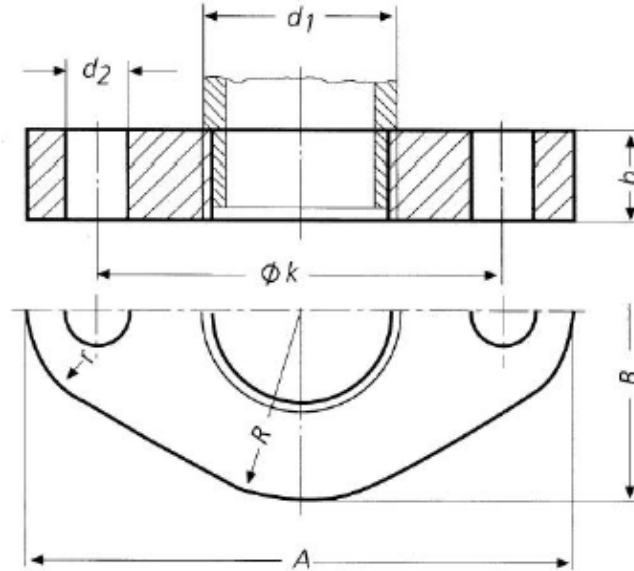

DN	d1	Thread DIN 2999	A	B	b	Øk	R	r	Thread	d2	KG
6	10.2	R 1/8	64	32	12	40	16	10	M10	11	0.119
8	13.5	R 1/4	72	36	12	45	18	11	M10	11	0.147
10	17.2	R 3/8	75	40	12	50	20	12	M10	11	0.165
15	21.3	R 1/2	80	45	12	55	22,5	13	M10	11	0.194
20	26.9	R 3/4	90	64	14	65	32	18	M10	11	0.373
25	33.7	R 1	100	72	14	75	36	20	M10	11	0.455
32	42.4	R 1-1/4	118	85	16	95	42.5	22	M12	14	0.675
40	48.3	R 1-1/2	132	95	16	100	47.5	25	M12	14	0.850
50	60.3	R 2	140	100	16	110	50	28	M12	14	0.882
65	76.1	R 2-1/2	160	118	16	130	59	32	M12	14	1.100
80	88.9	R 3	190	140	18	150	70	38	M16	18	1.760
100	114.3	R 4	210	160	18	170	80	42	M16	18	1.890

Dimensions in millimeter (mm).

DIN 2561 Oval Flange With Neck Threaded PN6 and PN10

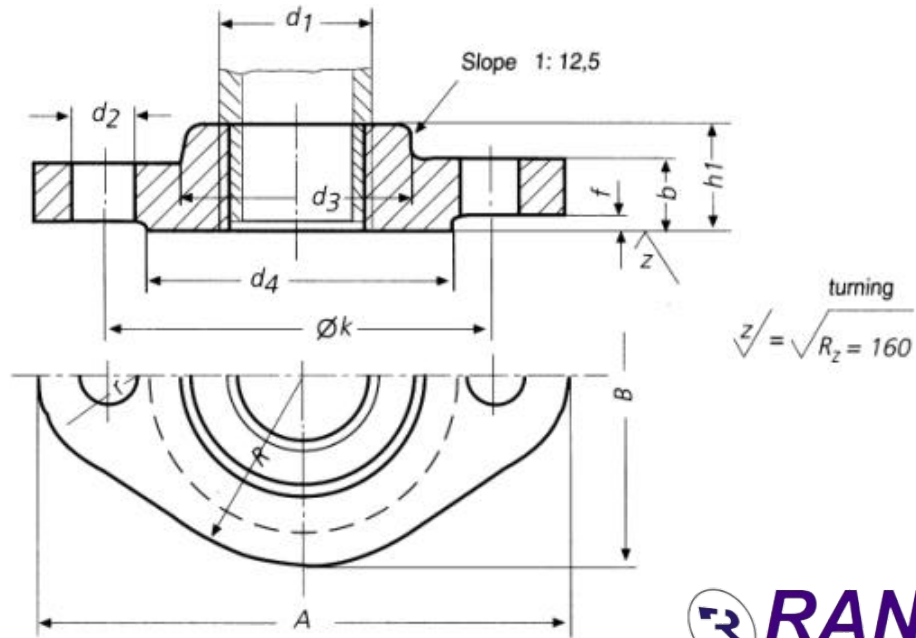

DN	d1	Thread DIN 2999	A	B	b	k	R	r	h1	d3	d4	f	Thread	d2	KG
6	10.2	R 1/8	75	40	12	50	20	12	18	20	32	2	M10	11	0.172
8	13.5	R 1/4	80	45	12	55	22,5	13	18	25	38	2	M10	11	0.21
10	17.2	R 3/8	90	50	14	60	25	15	20	30	40	2	M12	14	0.295
15	21.3	R 1/2	100	56	14	65	28	16	20	35	45	2	M12	14	0.365
20	26.9	R 3/4	105	75	16	75	37,5	21	24	45	58	2	M12	14	0.622
25	33.7	R 1	118	85	16	85	42,5	22	24	52	68	2	M12	14	0.777
32	42.4	R 1-1/4	140	100	16	100	50	28	26	60	78	2	M16	18	1.07
40	48.3	R 1-1/2	150	112	16	110	56	30	26	70	88	3	M16	18	1.26

Dimensions in millimeter (mm).

DIN 2565 Threaded Flange With Neck PN6

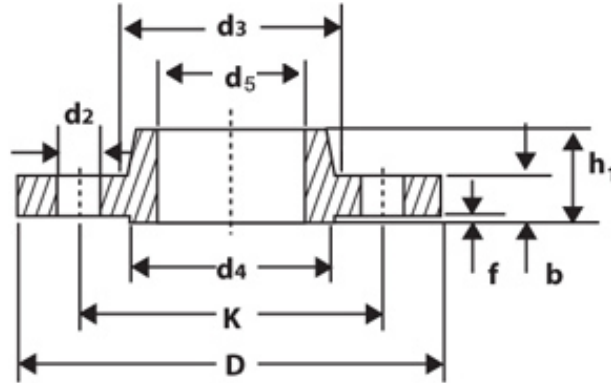

DN	D1	Thread DIN 2999	D	b	k	h	d3	d4	f	No. of holes	d2	KG
6	10.2	R1/8	65	10	40	18	18	25	2	4	11.5	0.19
8	13.5	R1/4	70	10	45	18	22	30	2	4	11.5	0.23
10	17.2	R3/8	75	12	50	20	25	35	2	4	11.5	0.32
15	21.3	R1/2	80	12	55	20	30	40	2	4	11.5	0.37
20	26.9	R3/4	90	14	65	24	40	50	2	4	11.5	0.58
25	33.7	R1	100	14	75	24	50	60	2	4	11.5	0.73
32	42.4	R1.1/4	120	14	90	26	60	70	2	4	14	1.05
40	48.3	R1.1/2	130	14	100	26	70	80	3	4	14	1.2
50	50.3	R2	140	14	110	28	80	90	3	4	14	1.54
65	76.1	R2.1/2	160	14	130	32	100	110	3	4	14	1.87
80	88.9	R3	190	16	150	34	110	128	3	4	18	2.78
100	114.3	R4	210	16	170	38	130	148	3	4	18	3.07
150	139.7	R5	240	18	200	40	160	178	3	8	18	4.33
200	168.3	R6	285	18	225	44	185	202	3	8	18	4.81

Dimensions in millimeter (mm).

DIN 2566 Threaded Flange With Neck PN16

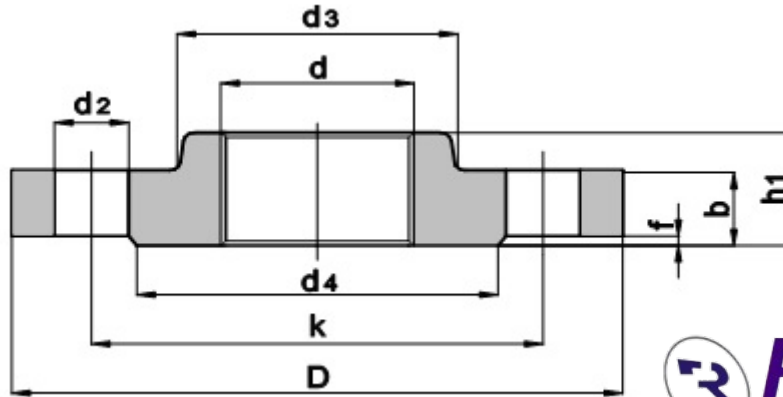

DN	d	Thread DIN 2999	D	b	k	h1	d3	d4	f	No. of holes	d2	KG
6	10.2	R1/8	75	12	50	18	20	32	2	4	11	0.33
8	13.5	R1/4	80	12	55	18	25	38	2	4	11	0.39
10	17.2	R3/8	90	14	60	20	30	40	2	4	14	0.56
15	21.3	R1/2	95	14	65	20	35	45	2	4	14	0.62
20	26.9	R3/4	105	16	75	24	45	58	2	4	14	0.92
25	33.7	R1	115	16	85	24	52	68	2	4	14	1.1
32	42.4	R1.1/4	140	16	100	26	60	78	2	4	18	1.59
40	48.3	R1.1/2	150	16	110	26	70	88	3	4	18	1.77
50	60.3	R2	165	18	125	28	85	102	3	4	18	2.41
65	76.1	R2.1/2	185	18	145	32	105	122	3	4	18	3.13
80	88.9	R3	200	20	160	34	118	138	3	4	18	3.95
100	114.3	R4	220	20	180	38	140	158	3	8	18	4.38
125	139.7	R3	250	22	210	40	168	188	3	8	18	5.99
150	168.3	R4	285	22	240	44	196	212	3	8	22	7.42

Dimensions in millimeter (mm).

DIN 2567 Threaded Flange With Neck PN25 and PN40

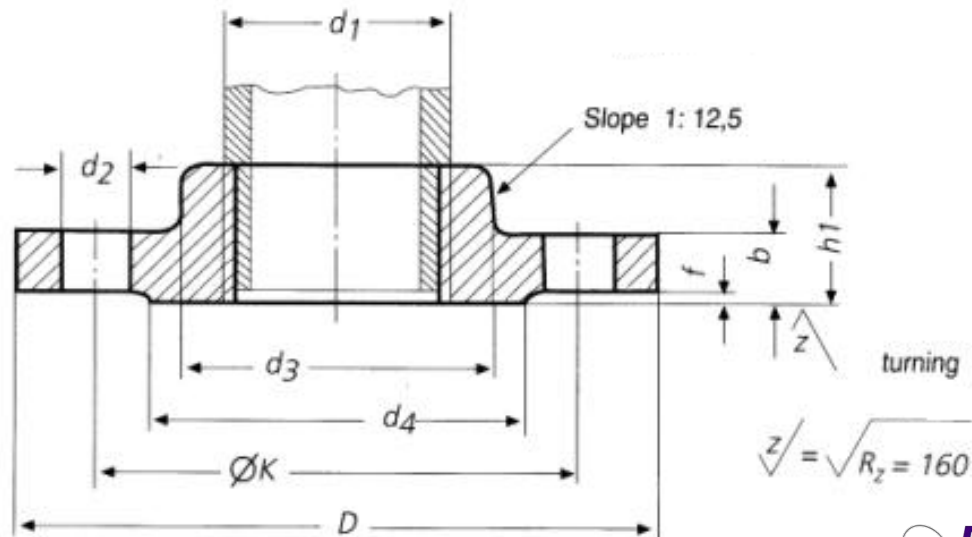

DN	d1	Thread DIN 2999	D	b	k	h1	d3	d4	f	No. of holes	Thread	d2	KG
6	10.2	R1/8	75	14	50	20	20	32	2	4	M10	11	0.388
8	13.5	R1/4	80	14	55	20	25	38	2	4	M10	11	0.450
10	17.2	R3/8	90	16	60	22	30	40	2	4	M12	14	0.630
15	21.3	R1/2	95	16	65	22	35	45	2	4	M12	14	0.710
20	26.9	R3/4	105	18	75	26	45	58	2	4	M12	14	1.030
25	33.7	R1	115	18	85	28	52	68	2	4	M12	14	1.280
32	42.4	R1.1/4	140	18	100	30	60	78	2	4	M16	18	1.870
40	48.3	R1.1/2	150	18	110	32	70	88	3	4	M16	18	2.140
50	60.3	R2	165	20	125	34	85	102	3	4	M16	18	2.850
65	76.1	R2.1/2	185	22	145	38	105	122	3	8	M16	18	3.850
80	88.9	R3	200	24	160	40	118	138	3	8	M16	18	4.800
100	114.3	R4	235	24	190	44	145	162	3	8	M20	22	6.430
125	139.7	R5	270	26	220	48	170	188	3	8	M24	26	8.770
150	165.1	R6	300	28	250	52	200	218	3	8	M24	26	10.500

Dimensions in millimeter (mm).

DIN 2568 Threaded Flange With Neck PN64

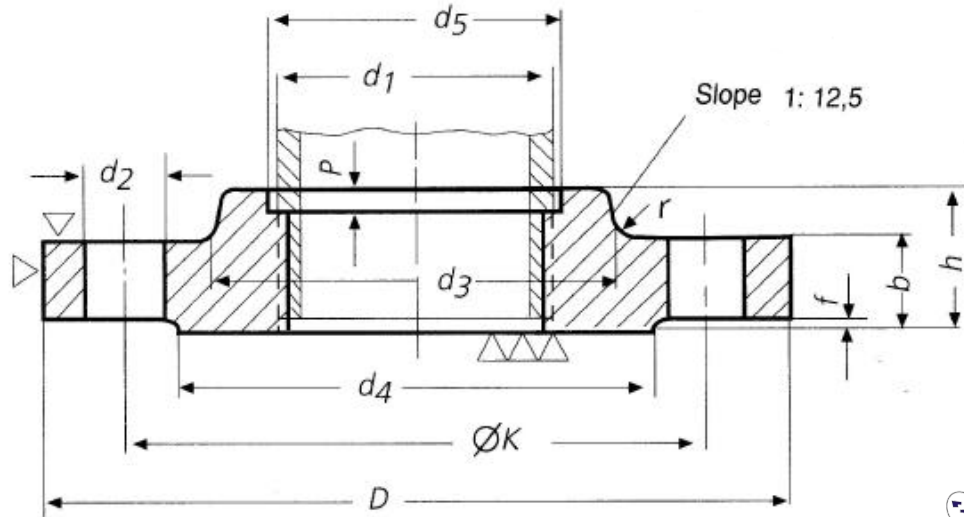

DN	d1	Thread DIN 2999	D	b	k	h1	d3	d5	P	r	d4	f	No. of holes	Thread	d2	KG
10 to 40	See DIN 2569															
50	60.3	R2	180	26	135	36	90	61	7	3	108	3	4	M20	22	4.29
65	76.1	R2.1/2	205	26	160	40	112	77	7	3	132	3	8	M20	22	5.48
80	88.9	R3	215	28	170	44	125	90	7	3	142	3	8	M20	22	6.42
100	114	R4	250	30	200	52	152	116	7	3	170	3	8	M24	26	9.25
125	140	R5	295	34	240	56	185	141	7	3	205	3	8	M27	30	14.4
150	165	R6	345	36	280	60	215	167	7	3	240	3	8	M30	33	20.7

Dimensions in millimeter (mm).

Tel: +919867815181

Email: sales@randhirmetal.com

Website: www.randhirmetal.com

DIN 2569 Threaded Flange With Neck PN100

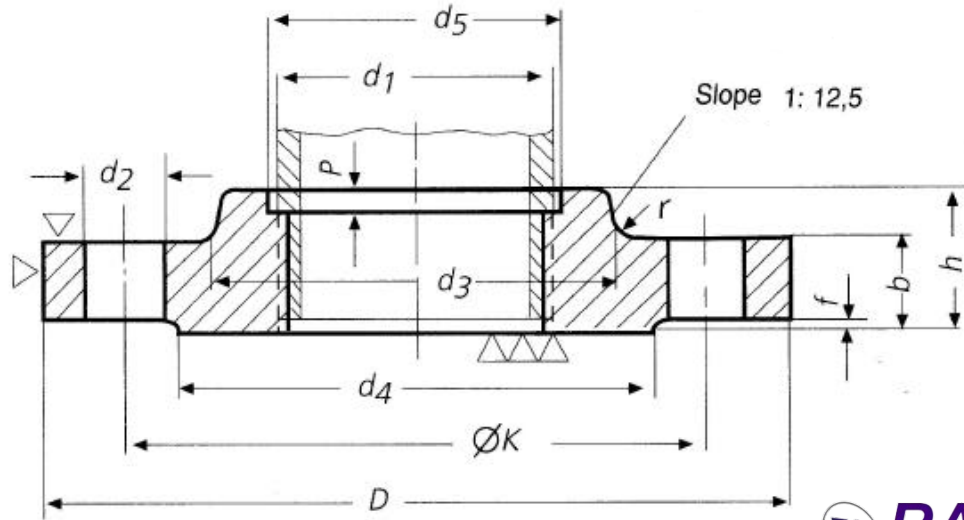

DN	d1	Thread DIN 2999	D	b	k	h1	d3	d5	P	r	d4	f	No. of holes	Thread	d2	KG
10	17.2	R3/8	100	20	70	28	40	18	4	2	50	2	4	M12	14	1.08
15	21.3	R1/2	105	20	75	28	43	22	6	2	55	2	4	M12	14	1.19
20	26.9	R3/4	130	22	90	30	52	28	7	2	68	2	4	M16	18	2.00
25	33.7	R1	140	24	100	32	60	35	7	3	78	2	4	M16	18	2.54
32	42.4	R1.1/4	155	24	110	32	68	43	7	3	85	2	4	M20	22	2.99
40	48.3	R1.1/2	170	26	125	34	80	49	7	3	98	3	4	M20	22	3.87
50	60.3	R2	195	28	145	36	95	61	7	3	115	3	4	M24	26	5.42
65	76.1	R2.1/2	220	30	170	40	118	77	7	3	140	3	8	M24	26	7.11
80	88.9	R3	230	32	180	44	130	90	7	3	150	3	8	M24	26	8.21
100	114	R4	265	36	210	52	158	116	7	3	175	3	8	M27	30	12.1
125	140	R5	315	40	250	56	188	141	7	3	210	3	8	M30	33	18.6
150	165	R6	355	44	290	60	225	167	7	3	250	3	12	M30	33	25.1

Dimensions in millimeter (mm).

Tel: +919867815181

Email: sales@randhirmetal.com

Website: www.randhirmetal.com

DIN 2573 Flat Flange For Welding (Slip On) PN6

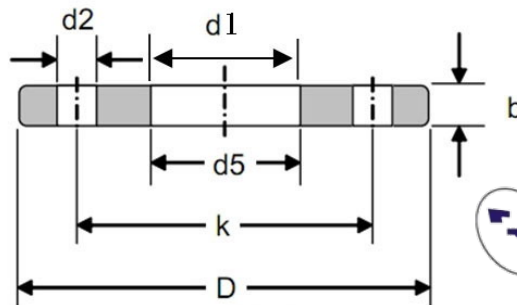

DN	Pipe OD		d5	D	b	k	No. of Holes	d2	KG
	ISO	DIN (d1)							
10	-	14	14.5	75	12	50	4	11	0.36
	17.2	-	17.7	75	12	50	4	11	0.36
15	-	20	21	80	12	55	4	11	0.41
	21.3	-	22	80	12	55	4	11	0.41
20	-	25	26	90	14	65	4	11	0.60
	26.9	-	27.6	90	14	65	4	11	0.59
25	-	30	31	100	14	75	4	11	0.74
	33.7	-	34.4	100	14	75	4	11	0.72
32	-	38	39	120	16	90	4	14	1.19
	42.4	-	43.1	120	16	90	4	14	1.16
40	-	44.5	45.5	130	16	100	4	14	1.39
	48.3	-	49	130	16	100	4	14	1.35
50	-	57	58.1	140	16	110	4	14	1.52
	60.3	-	61.1	140	16	110	4	14	1.49
65	76.1	-	77.1	160	16	130	4	14	1.86
80	88.9	-	90.3	190	18	150	4	14	2.96
100	-	108	109.6	210	18	170	4	18	3.42
	114.3	-	115.9	210	18	170	4	18	3.26
125	-	133	134.8	240	20	200	8	18	4.54
	139.7	-	141.6	240	20	200	8	18	4.31
150	-	159	161.1	265	20	225	8	18	5.34
	168.2	-	170.5	265	20	225	8	18	4.76
200	219.1	-	221.8	320	22	280	8	18	6.87
250	-	267	270.2	325	24	335	12	18	9.42
	273.0	-	276.2	325	24	335	12	18	8.94
300	323.9	-	327.6	440	24	395	12	22	11.91
350	355.6	-	359.7	480	26	445	12	22	16.52
	-	368	372.2	490	26	445	12	22	15.35
400	406.4	-	411	540	28	495	16	22	18.84
	-	419	423.7	540	28	495	16	22	18.01
450	457.0	-	462.3	595	30	550	16	22	24.52
500	508.0	-	513.6	645	30	600	20	22	26.37
600	610.0	-	616.5	755	32	705	20	26	34.80
700	711.0	-	*	860	40 / 36	810	24	26	*
800	813.0	-	*	975	44	920	24	30	*
900	914.0	-	*	1075	48	1020	24	30	*
1000	1016.0	-	*	1175	52	1120	28	30	*
1200	1219.0	-	*	1405	60	1340	32	33	*
1400	1422.0	-	*	1630	72	1560	36	36	*
1600	1626.0	-	*	1830	80	1760	40	36	*
1800	1829.0	-	*	2045	88	1970	44	39	*
2000	2032.0	-	*	2265	96	2180	48	42	*

Dimensions in millimeter (mm).

DIN 2576 Flat Flange For Welding (Slip On) PN10

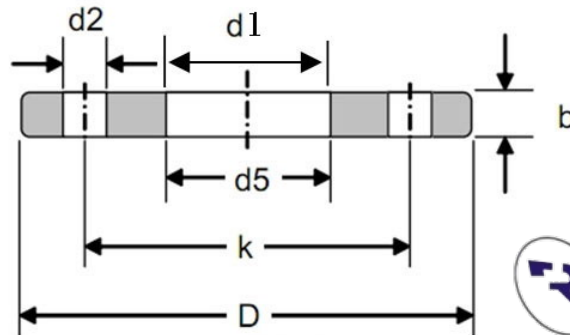

DN	Pipe OD		d5	D	b	k	No. of Holes	d2	KG
	ISO	DIN (d1)							
10	-	14	14.50	90	14	60	4	14	0.61
	17.2	-	17.70	90	14	60	4	14	0.60
15	-	20	21.00	95	14	65	4	14	0.67
	21.3	-	22.00	95	14	65	4	14	0.67
20	-	25	26.00	105	16	75	4	14	0.94
	26.9	-	27.60	105	16	75	4	14	0.94
25	-	30	31.00	115	16	85	4	14	1.13
	33.7	-	34.40	115	16	85	4	14	1.11
32	-	38	39.00	140	16	100	4	18	1.66
	42.4	-	43.10	140	16	100	4	18	1.62
40	-	44.5	45.50	150	16	110	4	18	1.89
	48.3	-	49.00	150	16	110	4	18	1.85
50	-	57	58.10	165	18	125	4	18	2.50
	60.3	-	61.10	165	18	125	4	18	2.46
65	76.1	-	77.10	185	18	145	4	18	2.99
80	88.9	-	90.30	200	20	160	8	18	3.61
100	-	108	109.60	220	20	180	8	18	4.17
	114.3	-	115.90	220	20	180	8	18	3.99
125	-	133	134.80	250	22	210	8	18	5.66
	139.7	-	141.60	250	22	210	8	18	5.41
150	-	159	161.10	285	22	240	8	22	6.97
	168.3	-	170.50	285	22	240	8	22	6.55
175	193.7	-	196.10	315	24	270	8	22	8.42
200	219.1	-	221.80	340	24	295	8	22	9.28
250	-	267	270.20	395	26	350	12	22	12.36
	273.0	-	276.20	395	26	350	12	22	11.85
300	323.9	-	327.60	445	26	400	12	22	13.61
350	355.6	-	359.70	505	28	460	16	22	20.35
	-	368	372.20	505	28	460	16	22	18.77
400	406.4	-	411.00	565	32	515	18	26	27.52
	-	419	423.70	565	32	515	18	26	35.43
450	457.0	-	462.30	615	38	565	20	26	35.11
500	508.0	-	513.60	670	38	620	20	26	40.20
600	610.0	-	615.50	780	42	725	20	26	51.87
700	711.0	-	*	895	50	840	24	30	*
800	813.0	-	*	1015	56	950	24	33	*
900	914.0	-	*	1115	62	1050	28	33	*
1000	1016.0	-	*	1230	70	1160	28	36	*
1200	1219.0	1220	*	1455	83	1380	32	39	*

Dimensions in millimeter (mm).

For DN10-DN40 use PN40; for DN50-DN200 use PN16.

Tel: +919867815181

Email: sales@randhirmetal.com

Website: www.randhirmetal.com

DIN 2627 Welding Neck Flange PN400

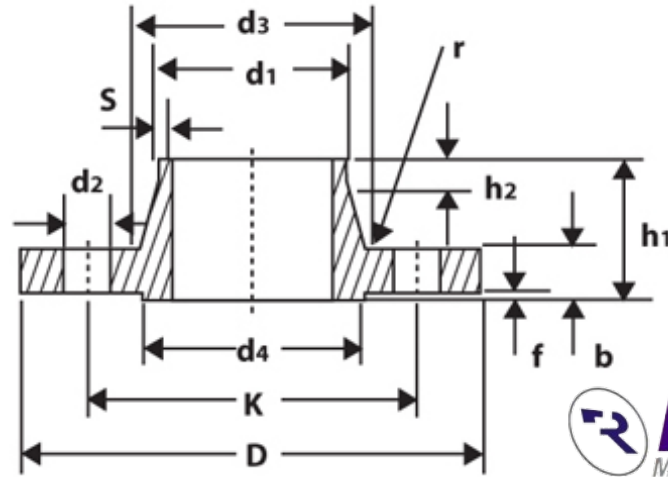

DN	d1 ISO	D	b	k	h1	d3	S	r	h2	d4	f	No. of holes	d2	KG
10	17.2	125	28	85	65	48	3.6	4	8	40	2	4	18	2.50
15	26.9	145	30	100	68	56	5.0	4	8	45	2	4	22	3.57
25	42.4	180	38	130	90	82	7.1	4	10	68	2	4	26	7.35
40	60.3	220	48	165	110	106	10.0	6	12	88	3	4	30	13.93
50	76.1	235	52	180	120	120	12.5	6	15	102	3	8	30	16.50
65	101.6	290	64	225	135	158	16.0	6	18	122	3	8	33	31.33
80	114.3	305	68	240	150	174	17.5	8	20	138	3	8	33	37.99
100	139.7	370	80	295	175	215	22.2	8	25	162	3	8	39	66.77
125	193.7	415	92	340	200	258	30.0	8	30	188	3	12	39	94.73
150	219.1	475	105	390	225	302	35.0	10	35	218	3	12	42	269.50
200	273.0	585	130	490	280	388	40.0	10	40	285	3	16	48	200.00

Dimensions in millimeter (mm).

DIN 2628 Welding Neck Flange PN250

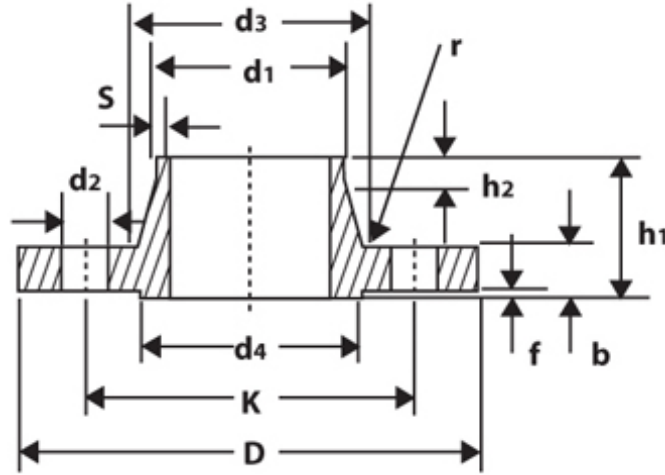

DN	d1		D	b	k	h1	d3	S	r	h2	d4	f	No. of holes	d2	KG
	ISO	DIN													
10	-	14	125	24	85	58	44	2.6	4	6	40	2	4	18	2.10
	17.2	-	125	24	85	58	44	2.6	4	6	40	2	4	18	2.09
15	-	20	130	26	90	60	48	2.6	4	6	45	2	4	18	2.48
	21.3	-	130	26	90	60	48	2.6	4	6	45	2	4	18	2.47
25	-	30	150	28	105	65	60	3.6	4	8	68	2	4	22	3.56
	33.7	-	150	28	105	65	60	3.6	4	8	68	2	4	22	3.53
40	-	44.5	185	34	135	80	84	5.0	6	10	88	3	4	26	6.65
	48.3	-	185	34	135	80	84	5.0	6	10	88	3	4	26	6.58
50	-	57	200	38	150	85	95	6.3	6	10	102	3	8	26	8.17
	60.3	-	200	38	150	85	95	6.3	6	10	102	3	8	26	8.09
65	76.1	-	230	42	180	95	124	8.0	6	12	122	3	8	26	12.59
80	101.6	-	255	46	200	102	136	11.0	8	12	138	3	8	30	16.32
100	127.0	-	300	54	235	120	164	14.2	8	14	162	3	8	33	27.07
125	152.4	-	340	60	275	140	200	16.0	8	16	188	3	12	33	38.79
150	177.8	-	390	68	320	160	240	17.5	10	18	218	3	12	36	59.05
200	244.5	-	485	82	400	190	305	25.0	10	25	285	3	12	42	109.45
250	298.5	-	585	100	490	215	385	32.0	12	30	345	3	16	48	189.94

Dimensions in millimeter (mm).

Tel: +919867815181

Email: sales@randhirmetal.com

Website: www.randhirmetal.com

DIN 2629 Welding Neck Flange PN320

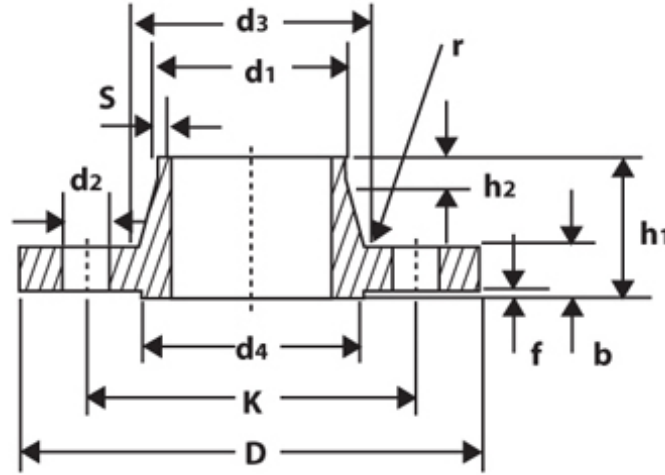

DN	d1		D	b	k	h1	d3	S	r	h2	d4	f	No. of holes	d2	KG
	ISO	DIN													
10.0	-	14	125	24	85	58	44	2.6	4	6	40	2	4	18	2.10
	17.2	-	125	24	85	58	44	2.6	4.0	6	40	2	4	18	2.09
15.0	-	20	130	26	90	60	48	3.2	4	6	45	2	4	18	2.49
	21.3	-	130	26	90	60	48	3.2	4.0	6	45	2	4	18	2.49
25.0	-	30	160	34	115	78	68	5.0	4	8	68	2	4	22	5.14
	33.7	-	160	34	115	78	68	5	4.0	8	68	2	4	22	5.11
40.0	-	44.5	195	38	145	88	92	6.3	6	10	88	3	4	26	8.53
	45.3	-	195	38	145	88	92	6.3	6.0	10	88	3	4	26	8.47
50.0	63.5	-	210	42	160	100	106	8.0	6	10	102	3	8	26	10.52
65.0	88.9	-	255	51	200	120	138	11.0	6	12	122	3	8	30	19.26
80.0	101.6	-	275	55	220	130	156	12.5	8	14	138	3	8	30	24.81
100.0	-	133	335	65	265	145	186	16.0	8	16	162	3	8	36	42.18
	125.0	-	380	75	310	175	230	20.0	8	20	188	3	12	36	64.55
	168.3	-	380	75	310	175	230	20	8.0	20	188	3	12	36	63.30
150.0	193.7	-	425	84	350	195	265	25.0	10	25	218	3	12	36	91.04
175.0	219.1	-	485	95	400	215	308	28.0	10	28	260	3	12	42	135.46
200.0	244.5	-	525	103	440	235	345	30.0	10	30	285	3	16	42	170.94
250.0	323.9	-	640	125	540	300	428	40.0	12	40	345	3	16	52	311.99

Dimensions in millimeter (mm).

Tel: +919867815181

Email: sales@randhirmetal.com

Website: www.randhirmetal.com

DIN 2630 Welding Neck Flange PN2.5

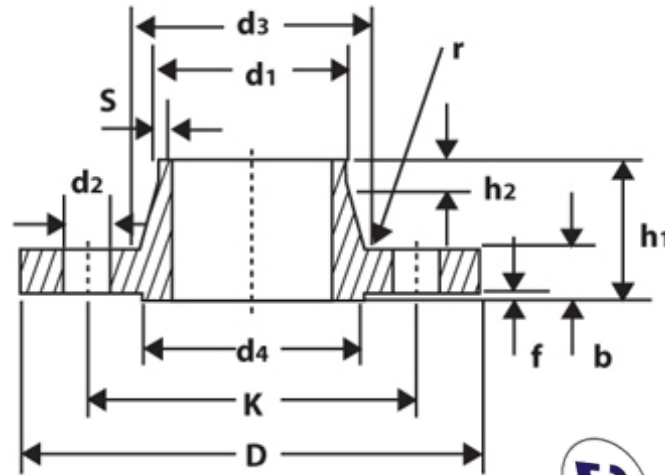

DN	d1		D	b	k	h1	D3	S	r	h2	d4	f	No. of Holes	d2	KG
	ISO	DIN													
10	-	14	75	12	50	28	22	1.8	4	6	35	2	4	11	0.34
	17.2	-	75	12	50	28	26	1.8	4	6	35	2	4	11	0.34
15	-	20	80	12	55	30	28	2	4	6	40	2	4	11	0.39
	21.3	-	80	12	55	30	30	2	4	6	40	2	4	11	0.46
20	-	25	90	14	65	32	35	2.3	4	6	50	2	4	11	0.6
	26.9	-	90	14	65	32	38	2.3	4	6	50	2	4	11	0.6
25	-	30	100	14	75	35	40	2.6	4	6	60	2	4	11	0.78
	33.7	-	100	14	75	35	42	2.6	4	6	60	2	4	11	0.78
32	-	38	120	14	90	35	50	2.6	6	6	70	2	4	14	1.07
	42.4	-	120	14	90	35	55	2.6	6	6	70	2	4	14	1.06
40	-	44.5	130	14	100	38	55	2.6	6	7	80	3	4	14	1.21
	48.3	-	130	14	100	38	62	2.6	6	7	80	3	4	14	1.2
50	-	57	140	14	110	38	70	2.9	6	8	90	3	4	14	1.37
	60.3	-	140	14	110	38	74	2.9	6	8	90	3	4	14	1.36
65	76.1	-	160	14	130	38	88	2.9	6	9	110	3	4	14	1.6
80	88.9	-	190	16	150	42	102	3.2	8	10	128	3	4	18	2.72
100	-	106	210	16	170	45	122	3.6	8	10	148	3	4	18	3.2
	114.3	-	210	16	170	45	130	3.6	8	10	148	3	4	18	3.22
125	-	133	240	18	200	48	148	4	8	10	178	3	8	18	4.58
	139.7	-	240	18	200	48	155	4	8	10	178	3	8	18	4.42
150	-	159	265	18	225	48	172	4.5	10	12	202	3	8	18	5.26
	166.3	-	265	18	225	48	184	4.5	10	12	202	3	8	18	5.04
200	219.1	-	320	20	280	55	236	5.9	10	15	258	3	8	18	7.95
250	-	267	375	22	335	60	282	6.3	12	15	312	3	12	18	11.16
	273	-	375	22	335	60	290	6.3	12	16	312	3	12	18	10.57
300	323.9	-	440	22	395	62	342	7.1	12	15	365	4	12	22	14.26
350	355.6	-	490	22	445	62	385	7.1	12	15	415	4	12	22	18.56
	-	368	490	22	445	62	385	7.1	12	15	415	4	12	22	16.76
400	406.4	-	540	22	495	65	438	7.1	12	15	465	4	16	22	21.25
	-	419	540	22	495	65	438	7.1	12	15	465	4	16	22	19.1

Dimensions in millimeter (mm).

DIN 2630 Welding Neck Flange PN2.5

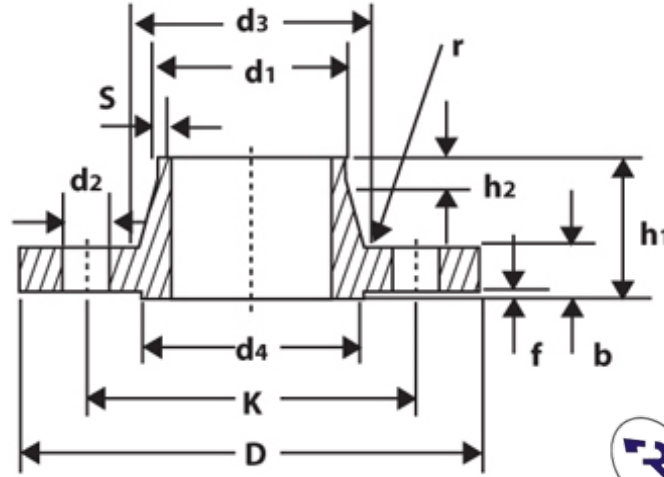

DN	d1		D	b	k	h1	D3	S	r	h2	d4	f	No. of Holes	d2	KG
	ISO	DIN													
500	506	-	645	24	600	68	538	7.1	12	15	570	4	20	22	23.57
600	610	-	755	24	705	70	640	7.1	12	16	670	5	20	26	34.5
700	711	-	660	24	810	70	740	7.1	12	16	775	5	24	26	40
800	813	-	975	24	920	70	842	7.1	12	16	880	5	24	30	48.18
900	914	-	1075	26	1020	70	942	7.1	12	16	980	5	24	30	58.1
1000	1016	-	1175	26	1120	70	1045	7.1	16	16	1080	5	25	30	63.41
1200	1220	-	1375	26	1320	70	1245	7	16	16	1280	5	32	30	72.82
1400	1420	-	1575	26	1520	70	1445	7	16	16	1480	5	36	30	84.5
1600	1620	-	1790	26	1730	80	1645	8	16	20	1680	5	40	30	111.57
1800	1820	-	1990	26	1930	80	1845	9	16	20	1890	5	44	30	128.41
2000	2020	-	2190	26	2130	80	2045	10	18	22	2090	5	48	30	145
2200	2220	-	2405	28	2340	90	2248	10	18	25	2295	6	52	33	184.1
2400	2420	-	2605	28	2540	90	2448	10	18	25	2495	6	56	32	200.47
2600	2620	-	2805	28	2740	90	2648	10	18	25	2695	6	60	33	216
2800	2820	-	3030	30	2960	90	2848	10	18	25	2910	6	64	36	268.05
3000	3020	-	3230	30	3160	90	3050	10	18	25	3110	6	66	36	285
3200	3220	-	3430	30	3350	90	3250	10	20	25	3310	6	72	36	306.75
3400	3420	-	3630	32	3560	95	3450	10	20	28	3510	6	76	36	346.71
3600	3620	-	3340	32	3770	100	3652	10	20	28	3720	6	80	36	305.71
3800	3820	-	4045	34	3970	100	3852	10	20	28	3920	6	80	-	-
4000	4020	-	4245	34	4170	100	4052	10	20	28	4120	6	84	-	-

DIN 2631 Welding Neck Flange PN6

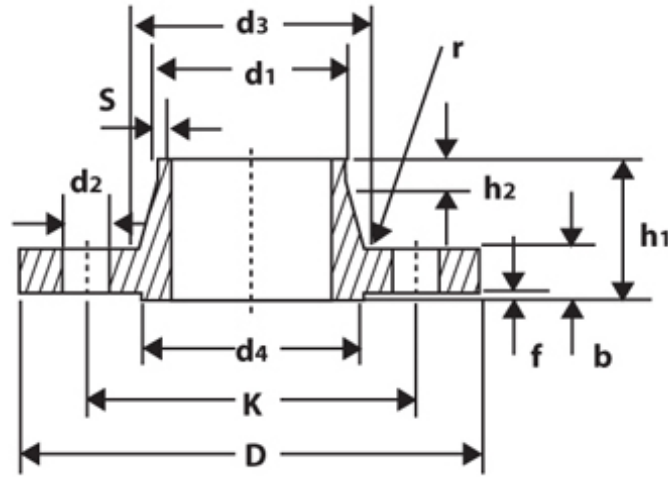

DN	d1		D	b	k	h1	d3	S	r	h2	d4	f	No. of holes	d2	KG
	ISO	DIN													
10	-	14	75	12	50	28	22	1.8	4	6	35	2	4	11	0.34
	17.2	-	75	12	50	28	26	1.8	4	6	35	2	4	11	0.34
15	-	20	80	12	55	30	28	2	4	6	40	2	4	11	0.39
	21.3	-	80	12	55	30	30	2	4	6	40	2	4	11	0.4
20	-	25	90	14	65	32	35	2.3	4	6	50	2	4	11	0.6
	26.9	-	90	14	65	32	38	2.3	4	6	50	2	4	11	0.6
25	-	30	100	14	75	35	40	2.6	4	6	60	2	4	11	0.76
	33.7	-	100	14	75	35	42	2.6	4	6	60	2	4	11	0.75
32	-	38	120	14	90	35	50	2.6	6	6	70	2	4	14	1.07
	42.4	-	120	14	90	35	55	2.6	6	6	70	2	4	14	1.06
40	-	44.5	130	14	100	38	58	2.6	6	7	80	3	4	14	1.21
	46.3	-	130	14	100	38	62	2.6	6	7	80	3	4	14	1.2
50	-	57	140	14	110	38	70	2.9	6	8	90	3	4	14	1.37
	60.3	-	140	14	110	38	74	2.9	6	8	90	3	4	14	1.36
65	76.1	-	160	14	130	38	88	2.9	6	9	110	3	4	14	1.69
80	88.9	-	190	16	150	42	102	3.2	8	10	128	3	4	18	2.72
100	-	108	210	16	170	45	122	3.6	8	10	148	3	4	18	3.29
	114.3	-	210	16	170	45	130	3.6	8	10	148	3	4	18	3.22
125	-	133	240	18	200	48	148	4	8	10	178	3	8	18	4.58
	139.7	-	240	18	200	48	155	4	8	10	178	3	8	18	4.42
150	-	159	265	18	225	48	172	4.5	10	12	202	3	8	18	5.26
	158.3	-	265	18	225	48	184	4.5	10	12	202	3	8	18	5.04
200	219.1	-	320	20	280	55	236	5.9	10	15	258	3	8	18	7.95
250	-	267	375	22	335	60	282	6.3	12	15	312	3	12	18	11.16
	273	-	375	22	335	60	290	6.3	12	15	312	3	12	18	10.87
300	323.9	-	440	22	395	62	342	7.1	12	15	365	4	12	22	14.26
350	355.6	-	490	22	445	62	385	7.1	12	15	415	4	12	22	18.54
	-	368	490	22	445	62	385	7.1	12	15	415	4	12	22	16.78
400	406.6	-	540	22	495	65	438	7.1	12	15	465	4	16	22	21.25
	-	419	540	22	495	65	438	7.1	12	15	465	4	16	22	19.1

Dimensions in millimeter (mm).

DIN 2631 Welding Neck Flange PN6

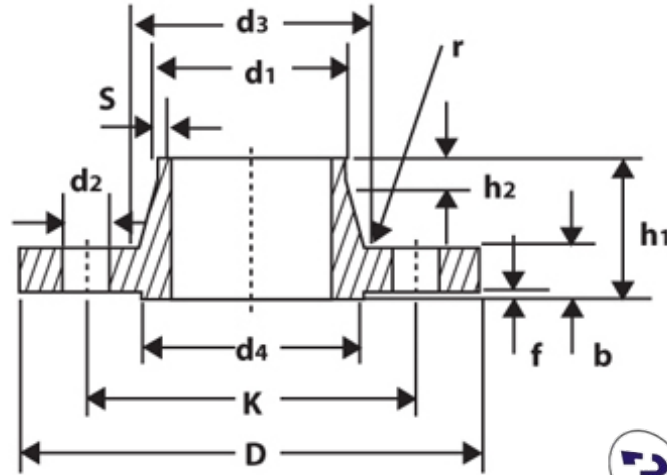

DN	d1		D	b	k	h1	d3	S	r	h2	d4	f	No. of holes	d2	KG
	ISO	DIN													
500	508	-	645	24	600	68	538	7.1	12	15	570	4	20	22	28.67
600	610	-	755	24	705	70	640	7.1	12	16	670	5	20	26	34.8
700	711	-	860	24	810	70	740	7.1	12	16	775	5	24	26	40.94
800	813	-	975	24	920	70	842	7.1	12	16	880	5	24	30	49.19
900	914	-	1075	26	1020	70	942	7.1	12	16	980	5	24	30	58.1
1000	1016	-	1175	26	1120	70	1045	7.1	16	16	1080	5	28	30	63.48
1200	1220	-	1405	28	1340	90	1248	8	16	20	1295	5	32	33	100.17
1400	1420	-	1630	32	1560	90	1452	8	16	20	1510	5	36	36	142.78
1600	1620	-	1830	34	1760	90	1655	9	16	20	1710	5	40	36	174.36
1800	1820	-	2045	36	1970	100	1855	10	16	20	1920	5	44	39	226.98
2000	2020	-	2265	38	2180	110	2058	11	16	25	2125	5	48	42	292.12
2200	2220	-	2475	42	2390	115	2260	12	18	25	2335	6	52	42	366.33
2400	2420	-	2685	44	2600	125	2462	13	18	25	2545	6	56	42	448.52
2600	2620	-	2905	46	2810	130	2665	14	18	25	2750	6	60	48	540.16
2800	2820	-	3115	48	3020	135	2865	15	18	30	2960	6	64	48	630.03
3000	3020	-	3315	50	3220	140	3068	16	18	30	3160	6	68	48	716.33
3200	3220	-	3525	54	3430	150	3272	16	20	30	3370	6	72	48	854.42
3400	3420	-	3735	46	3640	160	3475	18	20	35	3580	6	76	48	887.81
3600	3620	-	3970	60	3860	165	3678	18	20	35	3790	6	80	56	1202.43

Dimensions in millimeter (mm).

DIN 2632 Welding Neck Flange PN10

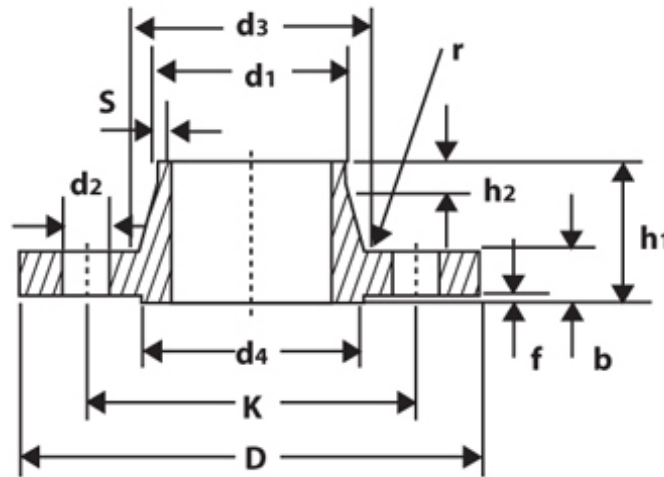

DN	d1		D	b	k	h1	d3	S	r	h2	d4	f	No. of holes	d2	KG
	ISO	DIN													
10	-	14	90	14	60	35	25	1.8	4	6	40	2	4	14	0.58
	17.2	-	90	14	60	35	28	1.8	4	6	40	2	4	14	0.58
15	-	20	95	14	65	35	30	2	4	6	45	2	4	14	0.65
	21.3	-	95	14	65	35	32	2	4	6	45	2	4	14	0.65
20	-	25	105	16	75	38	38	2.3	4	6	58	2	4	14	0.95
	26.9	-	105	16	75	38	40	2.3	4	6	58	2	4	14	0.95
25	-	30	115	16	85	38	42	2.6	4	6	68	2	4	14	1.15
	33.7	-	115	16	85	38	45	2.6	4	6	68	2	4	14	1.14
32	-	38	140	16	100	40	52	2.6	6	6	78	2	4	18	1.67
	42.4	-	140	16	100	40	55	2.6	6	6	78	2	4	18	1.65
40	-	44.5	150	16	110	42	60	2.6	6	7	88	3	4	18	1.85
	48.3	-	150	16	110	42	64	2.6	6	7	88	3	4	18	1.83
50	-	57	165	18	125	45	72	2.9	6	8	102	3	4	18	2.51
	60.3	-	165	18	125	45	75	2.9	6	8	102	3	4	18	2.48
65	76.1	-	165	18	145	45	90	2.9	6	10	122	3	4	18	3.03
80	88.9	-	200	20	160	50	105	3.2	6	10	138	3	8	18	3.82
100	-	108	220	20	180	52	125	3.6	8	12	158	3	8	18	4.54
	114.3	-	220	20	180	52	131	3.6	8	12	158	3	8	18	4.41
125	-	133	250	22	210	55	150	4	8	12	188	3	8	18	6.28
	139.7	-	250	22	210	55	156	4	8	12	188	3	8	18	6.07
150	-	159	285	22	240	55	175	4.5	10	12	212	3	8	22	7.75
	168.3	-	285	22	240	55	184	4.5	10	12	212	3	8	22	7.40
200	219.1	-	340	24	295	62	235	5.9	10	16	268	3	8	23	11.10
250	-	267	395	26	350	68	285	6.3	12	16	320	3	12	23	15.31
	273	-	395	26	350	68	292	6.3	12	16	320	3	12	23	14.92
300	323.9	-	445	26	400	68	344	7.1	12	16	370	4	12	23	17.47
350	355.6	-	505	26	460	66	385	7.1	12	16	430	4	16	23	23.7
	-	368	505	26	460	68	385	7.1	12	16	430	4	16	23	21.71
400	406.4	-	565	26	515	72	440	7.1	12	16	482	4	16	27	28.72
	-	419	565	26	515	72	440	7.1	12	16	482	4	16	27	26.27

Dimensions in millimeter (mm).

DIN 2632 Welding Neck Flange PN10

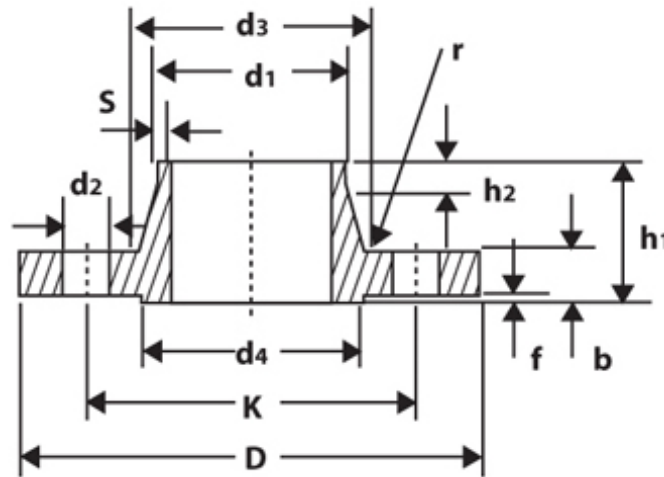

DN	d1		D	b	k	h1	d3	S	r	h2	d4	f	No. of holes	d2	KG
	ISO	DIN													
450	457.2	-	615	26	565	72	478	7.1	12	16	532	4	20	27	30.40
500	508	-	670	28	620	75	542	7.1	12	16	585	4	20	27	38.27
	-	521	670	28	620	75	542	7.1	12	16	585	4	20	27	38.27
600	610	-	780	28	725	80	642	7.1	12	18	685	5	20	30	46.56
700	711.2	-	895	30	840	80	745	8	12	18	800	5	24	30	62.30
	-	720	895	30	840	80	745	8	12	18	800	5	24	30	62.30
800	812.8	-	1015	32	950	90	850	8	12	18	905	5	24	33	83.81
	-	820	1015	32	950	90	850	8	12	18	905	5	24	33	83.81
900	914	-	1115	34	1050	95	950	10	12	20	1005	5	28	33	102.45
	-	920	1115	34	1050	95	950	10	12	20	1005	5	28	33	102.45
1000	1016	-	1230	34	1160	95	1052	10	16	20	1110	5	28	36	118.53
1200	1220	-	1455	36	1380	115	1255	11	16	25	1330	5	32	39	178.18
1400	1420	-	1675	42	1590	120	1460	12	16	25	1535	5	36	42	244.75
1600	1620	-	1915	46	1820	130	1665	14	16	25	1760	5	40	48	353.74
1800	1820	-	2115	50	2020	140	1868	15	16	30	1960	5	44	48	436.33
2000	2020	-	2325	54	2230	150	2072	16	16	30	2170	5	46	48	548.04
2200	2220	-	2550	58	2440	160	2275	18	18	35	2370	5	52	56	685.10
2400	2420	-	2760	62	2650	170	2478	20	18	35	2570	5	56	56	640.04
2600	2620	-	2860	66	2850	180	2690	22	18	40	2780	6	60	56	990.16
2800	2820	-	3180	70	3070	190	2882	22	18	40	3000	6	64	56	1187.16
3000	3020	-	3405	75	3290	200	3085	24	18	45	3210	6	65	62	1437.06

Dimensions in millimeter (mm).

DIN 2633 Welding Neck Flange PN16

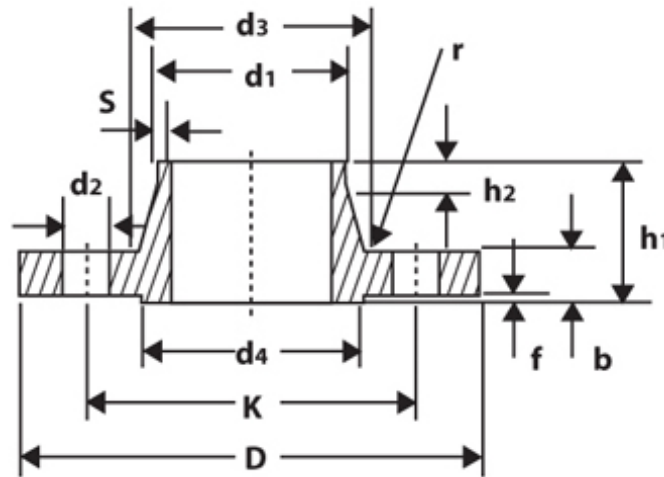

DN	d1		D	b	k	h1	d3	S	r	h2	d4	f	No. of holes	d2	KG
	ISO	DIN													
10	-	14	90	14	60	35	25	1.8	4	6	40	2	4	14	0.58
	17.2	-	90	14	60	35	28	1.8	4	6	40	2	4	14	0.58
15	-	20	95	14	65	35	30	2	4	6	45	2	4	14	0.65
	21.3	-	95	14	65	35	32	2	4	6	45	2	4	14	0.65
20	-	25	105	16	75	38	38	2.3	4	6	58	2	4	14	0.95
	26.9	-	105	16	75	38	40	2.3	4	6	58	2	4	14	0.95
25	-	30	115	16	85	38	42	2.6	4	6	68	2	4	14	1.15
	33.7	-	115	16	85	38	45	2.6	4	6	68	2	4	14	1.14
32	-	38	140	16	100	40	52	2.6	6	6	78	2	4	18	1.67
	42.4	-	140	16	100	40	56	2.6	6	6	78	2	4	18	1.65
40	-	44.5	150	16	110	42	60	2.6	6	7	88	3	4	18	1.85
	48.3	-	150	16	110	42	64	2.6	6	7	88	3	4	18	1.83
50	-	57	165	18	125	45	72	2.9	6	8	102	3	4	18	2.51
	60.3	-	165	18	125	45	75	2.9	6	8	102	3	4	18	2.48
65	76.1	-	185	18	145	45	90	2.9	6	10	122	3	4	18	3.03
80	88.9	-	200	20	160	50	105	3.2	8	10	138	3	8	18	3.82
100	-	108	220	20	180	52	125	3.6	8	12	158	3	8	18	4.54
	114.3	-	220	20	180	52	131	3.6	8	12	158	3	8	18	4.41
125	-	133	250	22	210	55	150	4	8	12	188	3	8	18	6.28
	139.7	-	250	22	210	55	156	4	8	12	188	3	8	18	6.07
150	-	159	285	22	240	55	175	4.5	10	12	212	3	8	23	7.75
	168.3	-	285	22	240	55	184	4.5	10	12	212	3	8	23	7.4
175	193.7	-	315	24	270	60	210	5.4	10	12	242	3	8	23	9.86
200	219.1	-	340	24	295	62	235	5.9	10	16	268	3	12	23	10.85

Dimensions in millimeter (mm).

DIN 2633 Welding Neck Flange PN16

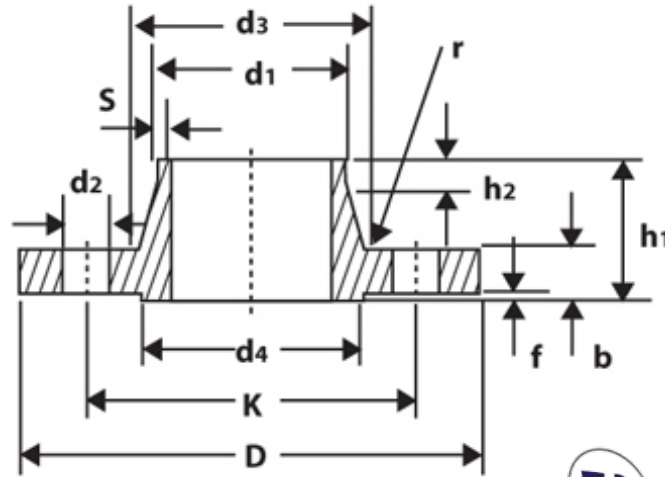

DN	d1		D	b	k	h1	d3	S	r	h2	d4	f	No. of holes	d2	KG
	ISO	DIN													
250	-	267	405	26	355	70	285	6.3	12	16	320	3	12	26	16.26
	273	-	405	26	355	70	292	6.3	12	16	320	3	12	26	15.87
300	323.9	-	460	28	410	78	344	7.1	12	16	378	4	12	26	21.24
350	355.6	-	520	30	470	82	390	8	12	16	438	4	16	26	31.38
	-	368	520	30	470	82	390	8	12	16	438	4	16	26	28.95
400	406.4	-	580	32	525	85	445	8	12	16	490	4	16	30	39.3
	-	419	580	32	525	85	445	8	12	16	490	4	16	30	36.3
500	508	-	715	34	650	90	548	8	12	16	610	4	20	33	59.63
600	610	-	840	36	770	95	652	8.8	12	18	725	5	20	36	82.54
700	711	-	910	36	840	100	755	8.8	12	18	795	5	24	36	83.9
800	813	-	1025	38	950	105	855	10	12	20	900	5	24	39	107.3
900	914	-	1125	40	1050	110	955	10	12	20	1000	5	28	39	124.97
1000	1016	-	1255	42	1170	120	1058	10	16	22	1115	5	28	42	163.76
1200	1220	-	1485	48	1390	130	1262	12.5	16	30	1330	5	32	48	244.15
1400	1420	-	1685	52	1590	145	1465	14.2	16	30	1530	5	36	48	320.87
1600	1620	-	1930	58	1820	160	1668	16	16	35	1750	5	40	56	465.83
1800	1820	-	2130	62	2020	170	1870	17.5	16	35	1950	5	44	56	570.52
2000	2020	-	2345	66	2230	180	2072	20	16	40	2150	5	48	62	706.74

Dimensions in millimeter (mm).

DIN 2634 Welding Neck Flange PN25

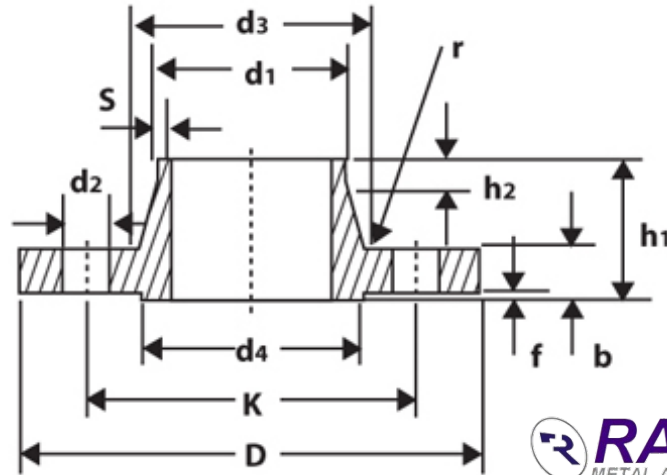

DN	d1		D	b	k	h1	d3	S	r	h2	d4	f	No. of holes	d2	KG
	ISO	DIN													
10	-	14	90	16	60	35	25	1.8	4	6	40	2	4	14	0.67
	17.2	-	90	16	60	35	28	1.8	4	6	40	2	4	14	0.66
15	-	20	95	16	65	38	30	2	4	6	45	2	4	14	0.75
	21.3	-	95	16	65	38	32	2	4	6	45	2	4	14	0.75
20	-	25	105	18	75	40	38	2.3	4	6	58	2	4	14	1.07
	26.9	-	105	18	75	40	40	2.3	4	6	58	2	4	14	1.07
25	-	30	115	18	85	40	42	2.6	4	6	68	2	4	14	1.29
	33.7	-	115	18	85	40	46	2.6	4	6	68	2	4	14	1.28
32	-	38	140	18	100	42	52	2.6	6	6	78	2	4	18	1.88
	42.4	-	140	18	100	42	56	2.6	6	6	78	2	4	18	1.86
40	-	44.5	150	18	110	45	60	2.6	6	7	88	3	4	18	2.1
	48.3	-	150	18	110	45	64	2.6	6	7	88	3	4	18	2.08
50	-	57	165	20	125	48	72	2.9	6	8	102	3	4	18	2.81
	60.3	-	165	20	125	48	75	2.9	6	8	102	3	4	18	2.78
65	76.1	-	185	22	145	52	90	2.9	6	10	122	3	8	18	3.61
80	88.9	-	200	24	160	58	105	3.2	8	12	138	3	8	18	4.62
100	-	106	235	24	190	65	128	3.6	8	12	162	3	8	22	6.42
	114.3	-	235	24	190	65	134	3.6	8	12	162	3	8	22	6.27
125	-	133	270	26	220	68	155	4	8	12	188	3	8	26	8.83
	139.7	-	270	26	220	68	162	4	8	12	188	3	8	26	8.61
150	-	159	300	28	250	75	182	4.5	10	12	218	3	8	26	11.67
	166.3	-	300	28	250	75	192	4.5	10	12	218	3	8	26	11.29
175	193.7	-	330	28	280	75	218	5.6	10	15	248	3	12	26	13.11
200	219.1	-	360	30	310	80	244	6.3	10	16	278	3	12	26	16.61
250	-	267	425	32	370	88	292	7.1	12	18	335	3	12	30	23.99
	273	-	425	32	370	88	298	7.1	12	18	335	3	12	30	23.48
300	323.9	-	485	34	430	92	352	8	12	18	395	4	16	30	30.74
350	355.6	-	555	38	490	100	398	8	12	20	450	4	16	33	47.20
	-	368	555	38	490	100	398	8	12	20	450	4	16	33	44.22
400	406.4	-	620	40	550	110	452	8.8	12	20	505	4	16	36	61.69
	-	419	620	40	550	110	452	8.8	12	20	505	4	16	36	57.88
500	508	-	730	44	660	125	558	10	12	20	615	4	20	36	89.57
600	610	-	845	46	770	125	660	11	12	20	720	5	20	39	114.96
700	711	-	960	46	875	125	760	12.5	12	20	820	5	24	42	139.5
800	813	-	1085	50	990	135	865	14.2	12	22	930	5	24	48	188.71
900	914	-	1185	54	1090	145	968	16	12	24	1030	5	28	48	231.48
1000	1016	-	1320	58	1210	155	1070	17.5	16	24	1140	5	28	56	303.52

Dimensions in millimeter (mm).

DIN 2635 Welding Neck Flange PN40

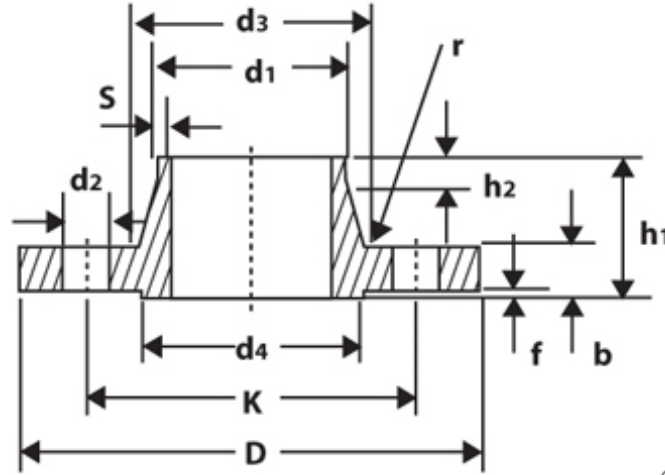

DN	d1		D	b	k	h1	d3	S	r	h2	d4	f	No. of holes	d2	KG
	ISO	DIN													
10	-	14	90	16	60	35	25	1.8	4	6	40	2	4	14	0.67
	17.2	-	90	16	60	35	28	1.8	4	6	40	2	4	14	0.66
15	-	20	95	16	65	38	30	2	4	6	45	2	4	14	0.75
	21.3	-	95	16	65	38	32	2	4	6	45	2	4	14	0.75
20	-	25	105	18	75	40	48	2.3	4	6	58	2	4	14	1.07
	26.9	-	105	18	75	40	40	2.3	4	6	58	2	4	14	1.07
25	-	30	115	18	85	40	42	2.6	4	6	68	2	4	14	1.29
	33.7	-	115	18	85	40	46	2.6	4	6	68	2	4	14	1.28
32	-	38	140	18	100	42	52	2.6	6	6	78	2	4	18	1.88
	42.4	-	140	18	100	42	56	2.6	6	6	78	2	4	18	1.86
40	-	44.5	150	18	110	45	60	2.6	6	7	88	3	4	18	2.1
	48.3	-	150	18	110	45	64	2.6	6	7	88	3	4	18	2.08
50	-	57	165	20	125	48	72	2.9	6	8	102	3	4	18	2.81
	60.3	-	165	20	125	48	75	2.9	6	8	102	3	4	18	2.78
65	-	76.1	185	22	145	52	90	2.9	6	10	122	3	8	18	3.81
	88.9	-	200	24	160	58	105	3.2	8	12	138	3	8	18	4.62
100	-	108	235	24	190	65	128	3.8	8	12	162	3	8	22	6.42
	114.3	-	235	24	190	65	134	3.6	8	12	162	3	8	22	6.27
125	-	133	270	26	220	68	155	4	8	12	188	3	8	26	8.83
	139.7	-	270	26	220	68	162	4	8	12	188	3	8	26	8.61
150	-	159	300	28	250	75	182	4.5	10	12	218	3	8	26	11.67
	168.3	-	300	28	250	75	192	4.5	10	12	218	3	8	26	11.29
175	193.7	-	350	32	295	82	218	5.6	10	15	260	3	12	30	17.01
	219.1	-	375	34	320	88	244	6.3	10	16	285	3	12	30	20.49
250	-	267	450	38	385	105	298	7.1	12	18	345	3	12	33	33.75
	273	-	450	38	385	105	306	7.1	12	18	345	3	12	33	33.34
300	323.9	-	515	42	450	115	362	8	12	18	410	4	16	33	46.55
	355.6	-	580	46	510	125	408	8.8	12	20	465	4	16	36	67.73
400	-	368	580	46	510	125	408	8.8	12	20	465	4	16	36	63.96
	406.4	-	660	50	585	135	462	11	12	20	535	4	16	39	96.73
500	-	419	660	50	585	135	462	11	12	20	535	4	16	39	91.99
	508	-	755	52	670	140	562	14.2	12	20	615	4	20	42	120.96

Dimensions in millimeter (mm).

DIN 2636 Welding Neck Flange PN64

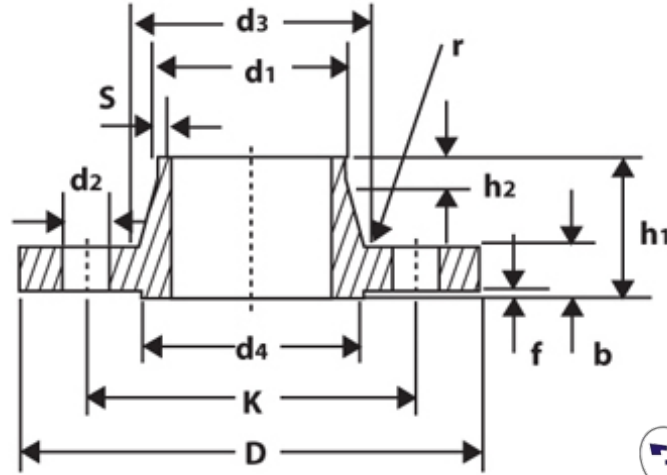

DN	d1		D	b	k	h1	d3	S	r	h2	d4	f	No. of holes	d2	KG
	ISO	DIN													
10	-	14	100	20	70	45	28	1.8	4	6	40	2	4	14	1.07
	17.2	-	100	20	70	45	32	1.8	4	6	40	2	4	14	1.08
15	-	20	105	20	75	45	32	2.0	4	6	45	2	4	14	1.19
	21.3	-	105	20	75	45	34	2.0	4	6	45	2	4	14	1.19
25	-	30	140	24	100	58	48	2.6	4	8	68	2	4	18	2.61
	33.7	-	140	24	100	58	52	2.6	4	8	68	2	4	18	2.60
40	-	44.5	170	26	125	62	65	2.9	6	10	88	3	4	22	4.00
	48.3	-	170	26	125	62	70	2.9	6	10	88	3	4	22	3.99
50	-	57	180	26	135	62	78	2.9	6	10	102	3	4	22	4.45
	60.3	-	180	26	135	62	82	2.9	6	10	102	3	4	22	4.42
65	76.1	-	205	26	160	66	98	3.2	6	12	122	3	8	22	5.49
80	88.9	-	215	28	170	72	112	3.6	8	12	138	3	8	22	6.50
100	-	108	250	30	200	76	132	4.0	8	12	162	3	8	26	9.25
	114.3	-	250	30	200	76	138	4.0	8	12	162	3	8	26	9.06
125	-	133	295	34	240	88	162	4.5	8	12	188	3	8	30	14.53
	139.7	-	295	34	240	88	168	4.5	8	12	188	3	8	30	14.23
150	-	159	345	36	280	95	192	5.6	10	12	218	3	8	33	21.35
	168.3	-	345	36	280	95	202	5.6	10	12	218	3	8	33	20.92
175	193.7	-	375	40	310	105	228	6.3	10	16	260	3	12	33	26.28
200	219.1	-	415	42	345	110	256	7.1	10	16	285	3	12	36	33.56
250	-	267	470	46	400	125	310	8.8	12	18	345	3	12	36	47.98
	273.0	-	470	46	400	125	316	8.8	12	18	345	3	12	36	47.32
300	323.9	-	530	52	460	140	372	11.0	12	18	410	4	16	36	66.44
350	355.6	-	600	56	525	150	420	12.5	12	20	465	4	16	39	96.23
	-	368	600	56	525	150	420	12.5	12	20	465	4	16	39	91.77
400	406.4	-	670	60	585	160	475	14.2	12	20	535	4	16	42	127.70
	-	419	670	60	585	160	475	14.2	12	20	535	4	16	42	122.13

Dimensions in millimeter (mm).

DIN 2637 Welding Neck Flange PN100

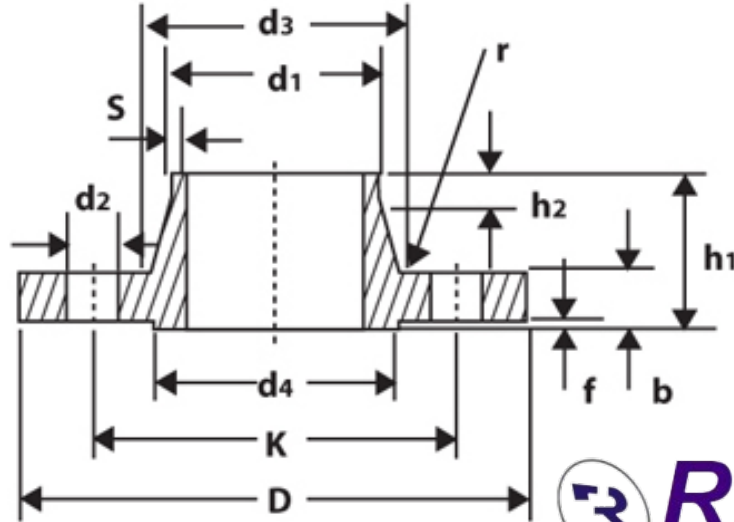

DN	d1		D	b	k	h1	d3	S	r	h2	d4	f	No. of holes	d2	KG
	ISO	DIN													
10	-	14	100	20	70	45	28	1.8	4	6	40	2	4	14	1.07
	17.2	-	100	20	70	45	32	1.8	4	6	40	2	4	14	1.08
15	-	20	105	20	75	45	32	2.0	4	6	45	2	4	14	1.19
	21.3	-	105	20	75	45	34	2.0	4	6	45	2	4	14	1.19
25	-	30	140	24	100	58	48	2.6	4	8	68	2	4	18	2.61
	33.7	-	140	24	100	58	52	2.6	4	8	68	2	4	18	2.60
40	-	44.5	170	26	125	62	65	2.9	6	10	88	3	4	22	4.00
	48.3	-	170	26	125	62	70	2.9	6	10	88	3	4	22	3.99
50	-	57	195	28	145	68	86	3.2	6	10	102	3	4	26	5.72
	60.3	-	195	28	145	68	90	3.2	6	10	102	3	4	26	5.70
65	76.1	-	220	30	170	76	108	3.6	6	12	122	3	8	26	7.43
	88.9	-	230	32	180	78	120	4.0	8	12	138	3	8	26	8.58
100	-	108	265	36	210	90	145	5.0	8	12	162	3	8	30	13.02
	114.3	-	265	36	210	90	150	5.0	8	12	162	3	8	30	12.79
125	-	133	315	40	250	105	180	6.3	8	12	188	3	8	33	21.29
	139.7	-	315	40	250	105	180	6.3	8	12	188	3	8	33	20.68
150	-	159	355	44	290	115	210	7.1	10	12	218	3	12	33	28.90
	168.3	-	355	44	290	115	210	7.1	10	12	218	3	12	33	27.76
175	193.7	-	385	48	320	127	245	8.8	10	16	260	3	12	33	36.94
200	219.1	-	430	52	360	130	278	10.0	10	16	285	3	12	36	49.35
250	-	267	505	60	430	157	340	12.5	12	18	345	3	12	39	81.71
	273.0	-	505	60	430	157	340	12.5	12	18	345	3	12	39	80.09
300	323.9	-	585	68	500	170	400	14.2	12	18	410	4	16	42	116.25
350	355.6	-	655	74	560	189	460	16.0	12	20	465	4	16	48	166.09
	-	368	655	74	560	189	460	16.0	12	20	465	4	16	48	160.53

Dimensions in millimeter (mm).

DIN 2638 Welding Neck Flange PN160

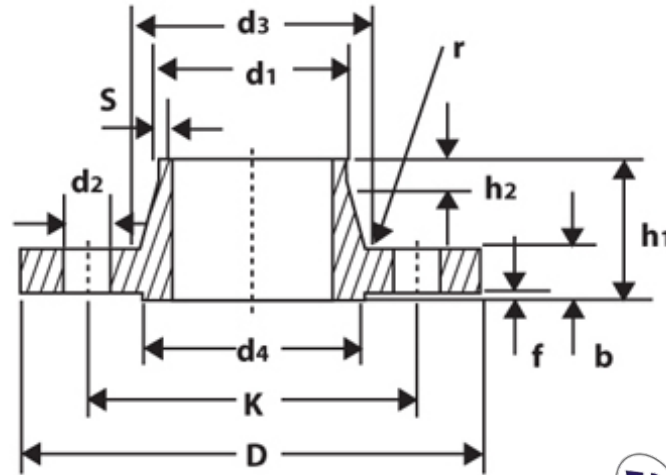

DN	d1		D	b	k	h1	d3	S	r	h2	d4	f	No. of holes	d2	KG
	ISO	DIN													
10	-	14	100	20	70	45	28	2.0	4	6	40	2	4	14	1.08
	17.2	-	100	20	70	45	32	2.0	4	6	40	2	4	14	1.08
15	-	20	105	20	75	45	32	2.0	4	6	45	2	4	14	1.19
	21.3	-	105	20	75	45	34	2.0	4	6	45	2	4	14	1.19
25	-	30	140	24	100	58	48	2.9	4	8	68	2	4	18	2.62
	33.7	-	140	24	100	58	52	2.9	4	8	68	2	4	18	2.62
40	-	44.5	170	28	125	64	65	3.6	6	10	88	3	4	22	4.36
	48.3	-	170	28	125	64	70	3.6	6	10	88	3	4	22	4.34
50	-	57	195	30	145	75	86	4.0	6	10	102	3	4	26	6.28
	60.3	-	195	30	145	75	90	4.0	6	10	102	3	4	26	6.27
65	76.1	-	220	34	170	82	108	5.0	6	12	122	3	8	26	8.61
80	88.9	-	230	36	180	86	120	6.3	8	12	138	3	8	26	10.09
100	-	108	265	40	210	100	145	8.0	8	12	162	3	8	30	15.28
	114.3	-	265	40	210	100	150	8.0	8	12	162	3	8	30	15.07
125	-	133	315	44	250	115	180	10.0	8	14	188	3	8	33	24.68
	139.7	-	315	44	250	115	180	10.0	8	14	188	3	8	33	24.09
150	-	159	355	50	290	128	210	12.5	10	14	218	3	12	33	35.14
	168.3	-	355	50	290	128	210	12.5	10	14	218	3	12	33	34.02
175	193.7	-	390	54	320	138	245	14.2	10	16	260	3	12	36	44.90
200	219.1	-	490	60	360	140	278	16.0	10	16	285	3	12	36	60.03
250	-	267	515	68	430	155	340	20.0	12	18	345	3	12	42	98.05
	273	-	515	68	430	155	340	20.0	12	18	345	3	12	42	96.52
300	323.9	-	585	76	500	175	400	22.2	12	18	410	4	16	42	138.80

Dimensions in millimeter (mm).

DIN 2641 Lapped (Lapped Joint) Flange, Plain Collar PN6

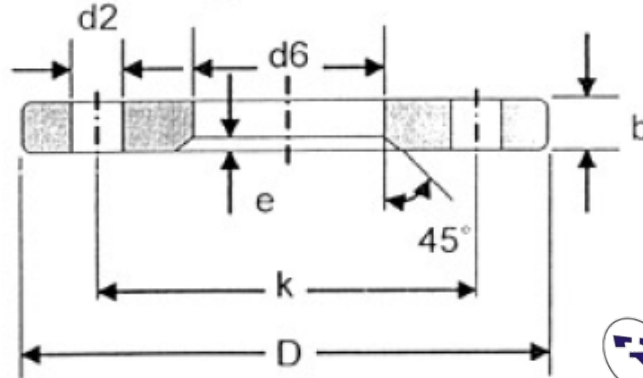

DN	Pipe OD		D	d6	b	k	e	No. of holes	d2	KG
	ISO	DIN								
10	-	14	75	16	10	50	2	4	11	0.3
	17.2	-	75	19	10	50	2	4	11	0.29
15	-	20	80	22	10	55	2	4	11	0.33
	21.3	-	80	24	10	55	2	4	11	0.33
20	-	25	90	28	10	65	2	4	11	0.42
	26.9	-	90	30	10	65	2	4	11	0.41
25	-	30	100	33	12	75	3	4	11	0.62
	33.7	-	100	36	12	75	3	4	11	0.61
32	-	38	120	42	12	90	3	4	14	0.88
	42.4	-	120	46	12	90	3	4	14	0.85
40	-	44.5	130	50	12	100	3	4	14	1.01
	48.3	-	130	54	12	100	3	4	14	0.98
50	-	57	140	62	12	110	3	4	14	1.11
	60.3	-	140	65	12	110	3	4	14	1.08
65	76.1	-	160	81	12	130	3	4	14	1.35
80	88.9	-	190	94	14	150	3	4	18	2.24
100	-	108	210	113	14	170	3	4	18	2.59
	114.3	-	210	119	14	170	3	4	18	2.47
125	-	133	240	138	14	200	3	8	18	3.1
	139.7	-	240	145	14	200	3	8	18	2.93
150	-	159	265	164	14	225	3	8	18	3.52
	168.3	-	265	173	14	225	3	8	18	3.25
200	219.1	-	320	225	16	280	3	8	18	4.85
250	-	267	375	273	20	335	3	12	18	7.67
	273	-	375	279	20	335	3	12	18	7.26
300	323.9	-	440	329	24	395	4	12	22	11.77
350	355.6	-	490	362	26	445	4	12	22	16.55
	-	368	490	374	26	445	4	12	22	15.13
400	406.4	-	540	413	28	495	4	16	22	19.56
	-	419	540	426	28	495	4	16	22	17.67
500	508	-	645	517	32	600	4	20	22	27.43
600	610	-	755	618	36	705	4	20	26	38.75
700	711	-	860	721	40	810	4	24	26	50.19
800	813	-	975	824	44	920	4	24	30	67.83
900	914	-	1075	926	48	1020	4	24	30	81.84
1000	1016	-	1175	1028	52	1120	4	28	30	95.74
1200	1220	-	1405	1232	60	1340	5	32	33	155.87

Dimensions in millimeter (mm).

DIN 2642 Lapped (Lapped Joint) Flange, Plain Collar PN10

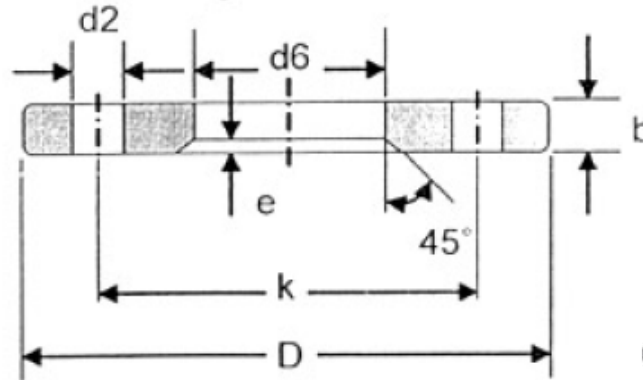

DN	Pipe OD		D	d6	b	k	e	No. of holes	d2	KG
	ISO	DIN								
10	-	14	90	16	14	60	3	4	14	0.61
	17.2	-	90	19	14	60	3	4	14	0.60
15	-	20	95	22	14	65	3	4	14	0.67
	21.3	-	95	24	14	65	3	4	14	0.66
20	-	25	105	28	14	75	3	4	14	0.82
	26.9	-	105	30	14	75	3	4	14	0.81
25	-	30	115	33	16	85	4	4	14	1.12
	33.7	-	115	36	16	85	4	4	14	1.10
32	-	38	140	42	16	100	4	4	18	1.63
	42.4	-	140	46	16	100	4	4	18	1.60
40	-	44.5	150	50	16	110	4	4	18	1.85
	48.3	-	150	54	16	110	4	4	18	1.80
50	-	57	165	62	16	125	5	4	18	2.18
	60.3	-	165	65	16	125	5	4	18	2.14
65	76.1	-	185	81	16	145	5	4	18	2.60
80	88.9	-	200	94	18	160	5	8	18	3.17
100	-	108	220	113	18	180	5	8	18	3.67
	114.3	-	220	119	18	180	5	8	18	3.51
125	-	133	250	138	18	210	5	8	18	4.53
	139.7	-	250	145	18	210	5	8	18	4.32
150	-	159	285	164	18	240	5	8	22	5.60
	168.3	-	285	173	18	240	5	8	22	5.26
200	219.1	-	340	225	20	295	5	8	22	7.53
250	-	267	395	273	22	350	5	12	22	10.27
	273	-	395	279	22	350	5	12	22	9.82
300	323.9	-	445	329	26	400	5	12	22	13.46
350	355.6	-	505	362	28	460	6	16	22	20.07
	-	368	505	374	28	460	6	16	22	18.54
400	406.4	-	565	413	32	515	6	16	26	27.19
	-	419	565	426	32	515	6	16	26	25.04
500	508	-	670	517	38	620	6	20	26	39.38
600	610	-	780	618	44	725	7	20	30	56.55
700	711	-	895	721	50	840	7	24	30	80.02
800	813	-	1015	824	56	950	7	24	33	112.25
900	914	-	1115	926	62	1050	7	28	33	135.80
1000	1016	-	1230	1026	70	1160	7	28	36	182.96

Dimensions in millimeter (mm).

DIN 2652 Loose Flange And Ring For Welding PN6

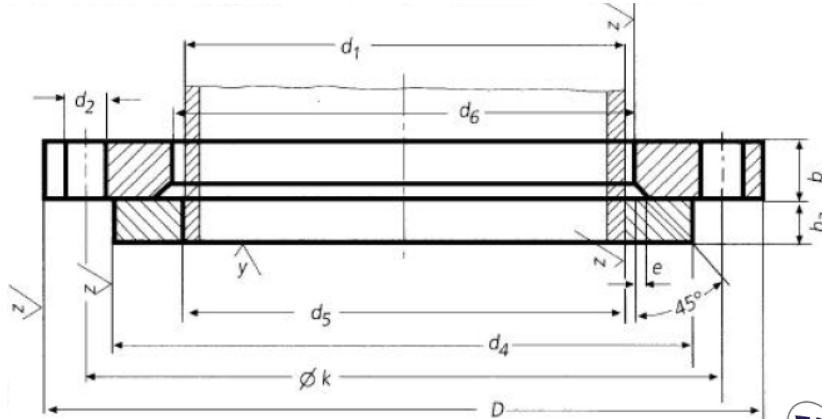

DN	d1		D	d6	b	k	e	No. of holes	Thread	d2	d4	d5	h3	KG Flange	KG Ring
	ISO	DIN													
10	-	14	75	16	10	50	5	4	M10	11	35	14.5	8	0.298	0.051
	17.2	-	75	19	10	50	5	4	M10	11	35	17.7	8	0.298	0.051
15	-	20	80	22	10	55	5	4	M10	11	40	21	8	0.337	0.063
	21.3	-	80	24	10	55	5	4	M10	11	40	22	8	0.337	0.063
20	-	25	90	28	10	65	5	4	M10	11	50	26	10	0.418	0.116
	26.9	-	90	30	10	65	5	4	M10	11	50	27.6	10	0.418	0.116
25	-	30	100	33	12	75	6	4	M10	11	60	31	10	0.620	0.166
	33.7	-	100	36	12	75	6	4	M10	11	60	34.4	10	0.620	0.166
32	-	38	120	42	12	90	6	4	M12	14	70	39	10	0.874	0.213
	42.4	-	120	46	12	90	6	4	M12	14	70	43.1	10	0.874	0.213
40	-	44.5	130	50	12	100	6	4	M12	14	80	45.5	10	1.010	0.273
	48.3	-	130	54	12	100	6	4	M12	14	80	49	10	1.010	0.273
50	-	57	140	62	12	110	6	4	M12	14	90	58.1	12	1.120	0.359
	60.3	-	140	65	12	110	6	4	M12	14	90	61.1	12	1.120	0.359
65	76.1	-	160	81	12	130	6	4	M12	14	110	77.1	12	1.350	0.468
80	88.9	-	190	94	14	150	6	4	M16	18	128	90.3	14	2.240	0.730
100	-	108	210	113	14	170	6	4	M16	18	148	109.6	14	2.590	0.884
	114.3	-	210	119	14	170	6	4	M16	18	148	115.9	14	2.590	0.884
125	-	133	240	138	14	200	6	8	M16	18	178	134.8	14	3.100	1.210
	139.7	-	240	145	14	200	6	8	M16	18	178	141.6	14	3.100	1.210
150	-	159	265	164	14	225	6	8	M16	18	202	161.1	14	3.520	1.340
	168.3	-	265	173	14	225	6	8	M16	18	202	170.5	14	3.520	1.340
200	219.1	-	320	225	16	280	8	8	M16	18	258	221.8	16	4.980	2.000
250	-	267	375	273	20	335	8	8	M16	18	312	270.2	18	7.670	2.890
	273	-	375	279	20	335	8	12	M16	18	312	276.2	18	7.670	2.890
300	323.9	-	440	329	24	395	8	12	M20	22	365	327.6	18	12.30	3.560
350	355.6	-	590	362	26	445	8	12	M20	22	415	359.7	18	15.10	4.080
	-	368	590	374	26	445	8	12	M20	22	415	372.2	18	15.10	4.080
400	406.4	-	540	413	28	495	8	16	M20	22	465	411	20	17.70	4.910
	-	419	540	426	28	495	8	16	M20	22	465	423.7	20	17.70	4.910
(450)	457	-	595	467	30	550	8	16	M20	22	520	462.5	20	20.40	5.700
500	508	-	645	517	32	600	8	20	M20	22	570	513.6	22	25.40	7.390

Dimensions in millimeter (mm).

Tel: +919867815181

Email: sales@randhirmetal.com

Website: www.randhirmetal.com

DIN 2653 Loose Flange And Ring For Welding PN10

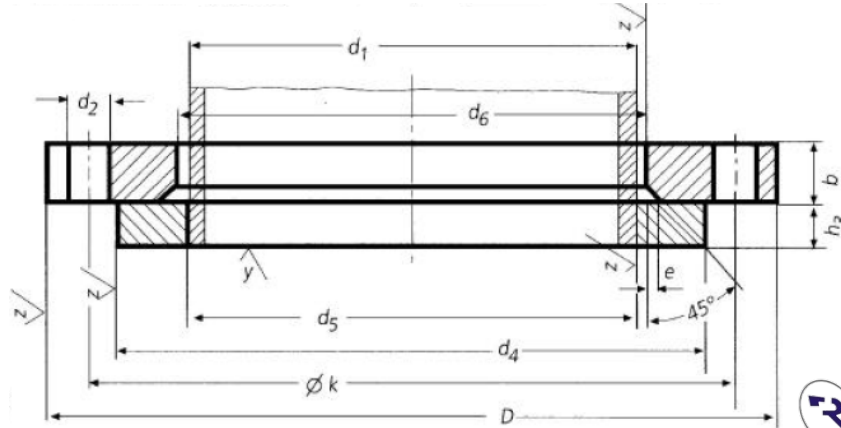

DN	d1		D	d6	b	k	e	No. of holes	Thread	d2	d4	d5	h3	KG Flange	KG Ring
	ISO	DIN													
10	-	14	90	16	14	60	5	4	M12	14	40	14.5	10	0.599	0.087
	17.2	-	90	19	14	60	5	4	M12	14	40	17.7	10	0.599	0.087
15	-	20	95	22	14	65	5	4	M12	14	45	21	10	0.689	0.105
	21.3	-	95	24	14	65	5	4	M12	14	45	22	10	0.689	0.105
20	-	25	105	28	14	75	5	4	M12	14	58	26	12	0.806	0.203
	26.9	-	105	30	14	75	5	4	M12	14	58	27.6	12	0.806	0.203
25	-	30	115	33	16	85	6	4	M12	14	68	31	12	0.110	0.276
	33.7	-	115	36	16	85	6	4	M12	14	68	34.4	12	0.110	0.276
32	-	38	140	42	16	100	6	4	M16	18	78	39	12	1.640	0.343
	42.4	-	140	46	16	100	6	4	M16	18	78	43.1	12	1.640	0.343
40	-	44.5	150	50	16	110	6	4	M16	18	88	45.5	12	1.860	0.426
	48.3	-	150	54	16	110	6	4	M16	18	88	49	12	1.860	0.426
50	-	57	165	62	16	125	6	4	M16	18	102	58.1	14	2.200	0.618
	60.3	-	165	65	16	125	6	4	M16	18	102	61.1	14	2.200	0.618
65	76.1	-	185	81	16	145	6	4	M16	18	122	77.1	14	2.620	0.786
80	88.9	-	200	94	18	160	6	4	M16	18	138	90.3	16	3.320	1.100
100	-	108	220	113	18	180	6	4	M16	18	158	109.6	16	3.670	1.310
	114.3	-	220	119	18	180	6	4	M16	18	158	115.9	16	3.670	1.310
125	-	133	250	138	18	210	6	8	M16	18	188	134.8	18	4.540	1.960
	139.7	-	250	145	18	210	6	8	M16	18	188	141.6	18	4.540	1.960
150	-	159	285	164	18	240	6	8	M20	22	212	161.1	18	5.600	2.180
	168.3	-	285	173	18	240	6	8	M20	22	212	170.5	18	5.600	2.180
200	219.1	-	340	225	20	295	8	8	M20	22	268	221.8	20	7.460	3.100
	-	267	395	273	22	350	8	8	M20	22	320	270.2	22	10.30	4.220
250	-	273	395	279	22	350	8	12	M20	22	320	276.2	22	10.30	4.220
	323.9	-	445	329	26	400	8	12	M20	22	370	327.6	22	14.00	4.850
350	355.6	-	505	362	28	460	8	12	M20	22	430	359.7	22	18.50	6.710
	-	368	505	374	28	460	8	12	M20	22	430	372.2	22	18.50	6.710
400	406.4	-	565	413	32	515	8	16	M24	26	482	411	24	25.00	8.280
	-	419	565	426	32	515	8	16	M24	26	482	423.7	24	25.00	8.280
(450)	457	-	615	467	38	565	8	16	M24	26	532	462.5	24	30.60	9.300
500	508	-	670	517	38	620	8	20	M24	26	585	513.6	26	37.00	11.50

Dimensions in millimeter (mm).

Tel: +919867815181

Email: sales@randhirmetal.com

Website: www.randhirmetal.com

DIN 2655 Lapped (Lapped Joint) Flange, Plain Collar PN25

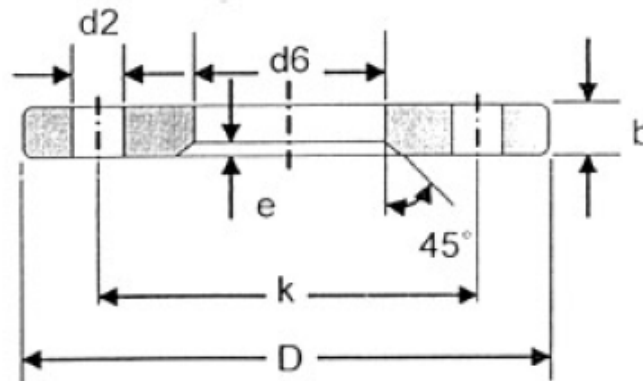

DN	Pipe OD		D	d6	b	k	e	No. of holes	d2	KG
	ISO	DIN								
10	-	14	90	16	16	60	5	4	14	0.7
	17.2	-	90	19	16	60	5	4	14	0.69
15	-	20	95	22	16	65	5	4	14	0.77
	21.3	-	95	24	16	65	5	4	14	0.76
20	-	25	105	28	16	75	5	4	14	0.93
	26.9	-	105	30	16	75	5	4	14	0.92
25	-	30	115	33	18	85	6	4	14	1.26
	33.7	-	115	36	18	85	6	4	14	1.24
32	-	38	140	42	18	100	6	4	18	1.84
	42.4	-	140	46	18	100	6	4	18	1.8
40	-	44.5	150	50	18	110	6	4	18	2.08
	48.3	-	150	54	18	110	6	4	18	2.03
50	-	57	165	62	20	125	6	4	18	2.72
	60.3	-	165	65	20	125	6	4	18	2.68
65	76.1	-	185	81	20	145	6	8	18	3.09
80	88.9	-	200	94	22	160	6	8	18	3.88
100	-	108	235	113	22	190	6	8	22	5.23
	114.3	-	235	119	22	190	6	8	22	5.04
125	-	133	270	138	24	220	6	8	26	7.17
	139.3	-	270	145	24	220	6	8	26	6.88
150	-	159	300	164	24	250	6	8	26	8.54
	166.3	-	300	173	24	250	6	8	26	8.08
200	219.1	-	360	225	26	310	8	12	26	11.36
250	-	267	425	273	30	370	8	12	30	17.63
	273	-	425	279	30	370	8	12	30	17.01
300	323.9	-	485	329	34	430	8	16	30	23.6
350	355.6	-	555	362	38	490	8	16	33	37.38
	-	363	555	374	38	490	8	16	33	35.31
400	406.4	-	620	413	42	550	8	16	36	50
	-	419	620	426	42	550	8	16	36	47.18
500	508	-	730	517	50	660	8	20	36	73.88

Dimensions in millimeter (mm).

Tel: +919867815181

Email: sales@randhirmetal.com

Website: www.randhirmetal.com

DIN 2656 Lapped (Lapped Joint) Flange, Plain Collar PN40

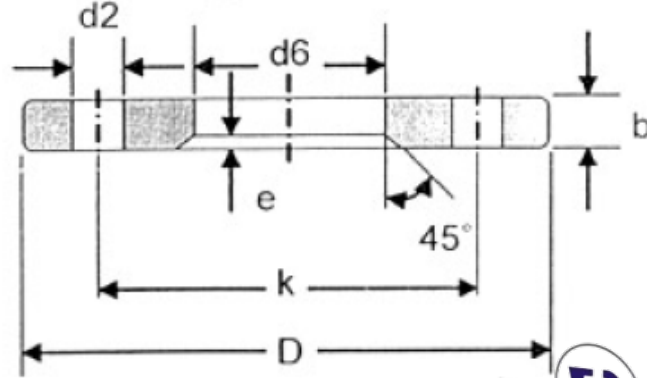

DN	Pipe OD		D	d6	b	k	e	No. of holes	d2	KG
	ISO	DIN								
10	-	14	90	16	16	60	5	4	14	0.7
	17.2	-	90	19	16	60	5	4	14	0.69
15	-	20	95	22	16	65	5	4	14	0.77
	21.3	-	95	24	16	65	5	4	14	0.76
20	-	25	105	28	16	75	5	4	14	0.93
	26.9	-	105	30	16	75	5	4	14	0.92
25	-	30	115	33	18	85	6	4	14	1.26
	33.7	-	115	36	18	85	6	4	14	1.24
32	-	38	140	42	18	100	6	4	18	1.84
	42.4	-	140	46	18	100	6	4	18	1.8
40	-	44.5	150	50	18	110	6	4	18	2.08
	48.3	-	150	54	18	110	6	4	18	2.03
50	-	57	165	62	20	125	6	4	18	2.72
	60.3	-	165	65	20	125	6	4	18	2.68
65	76.1	-	165	81	20	145	6	8	18	3.09
80	88.9	-	200	94	22	160	6	8	18	3.88
100	-	108	235	113	22	190	6	8	22	5.23
	114.3	-	235	119	22	190	6	8	22	5.04
125	-	133	270	138	24	220	6	8	26	7.17
	139.7	-	270	145	24	220	6	8	26	6.88
150	-	159	300	164	24	250	6	8	26	8.54
	168.3	-	300	173	24	250	6	8	26	8.09
200	219.1	-	375	225	30	320	8	12	30	14.65
250	-	267	450	273	36	385	8	12	33	25.5
	273	-	450	279	36	385	8	12	33	24.77
300	323.9	-	515	329	40	450	8	16	33	34.42
350	355.8	-	580	362	46	510	8	16	36	52.36
	-	363	580	374	46	510	8	16	36	49.85
400	406.4	-	660	413	50	585	8	16	39	74.2
	-	419	660	426	50	585	8	16	39	70.84

Dimensions in millimeter (mm).

DIN 2673 Loose Flange And Ring With Neck For Welding PN10

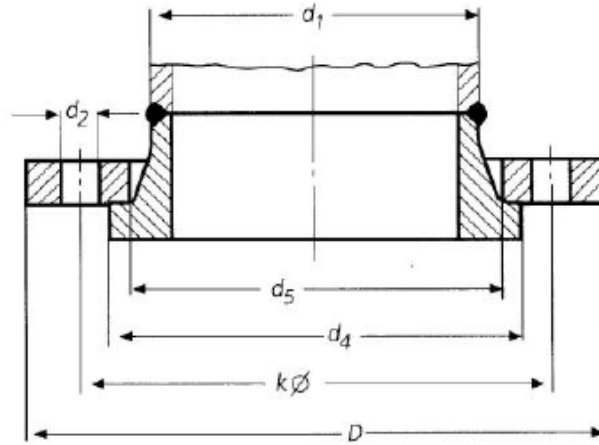

Welding ends
DIN 2559

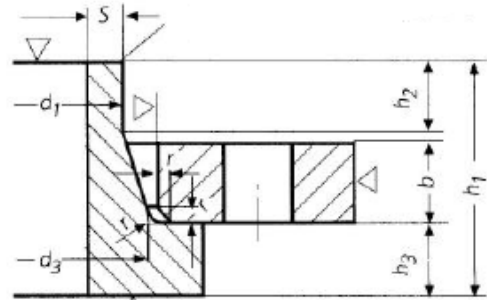

DN	d1	D	d5	b	k	No. of holes	Thread	d2	d4	h1	h3	d3	S	r	h2	KG Flange	KG Ring
10	14	90	25	14	60	4	M12 1/2"	14	40	35	10	22	1.8	2	6	0,566	0,117
	17,2	90	28	14	60	4	M12 1/2"	14	40	35	10	25	1.8	2	6	-	-
15	20	95	32	14	65	4	M12 1/2"	14	45	35	10	28	2	2	6	0,622	0,151
	21,3	95	34	14	65	4	M12 1/2"	14	45	35	10	30	2	2	6	-	-
20	25	105	38	14	75	4	M12 1/2"	14	58	40	12	35	2.3	2	6	0,747	0,273
	26,9	105	40	14	75	4	M12 1/2"	14	58	40	12	37	2.3	2	6	-	-
25	30	115	45	16	85	4	M12 1/2"	14	68	40	12	40	2.6	2	6	1,01	0,372
	33,7	115	48	16	85	4	M12 1/2"	14	68	40	12	43	2.6	2	6	-	-
32	38	140	55	16	100	4	M16 5/8"	18	78	40	12	50	2.6	2	6	1,5	0,485
	42,4	140	60	16	100	4	M16 5/8"	18	78	40	12	54	2.6	2	6	-	-
40	44,5	150	62	16	110	4	M16 5/8"	18	88	40	12	58	2.6	2	7	1,71	0,61
	48,3	150	66	16	110	4	M16 5/8"	18	88	40	12	62	2.6	2	7	-	-
50	57	165	75	16	125	4	M16 5/8"	18	102	45	14	70	2.9	2	8	2	0,888
	60,3	165	78	16	125	4	M16 5/8"	18	102	45	14	73	2.9	2	8	-	-
65	76,1	185	92	16	145	4	M16 5/8"	18	122	45	14	88	2.9	2	10	2,41	1,13
80	88,9	200	108	18	160	4	M16 5/8"	18	138	50	16	102	3.2	2	10	3	1,6
100	108	220	128	18	180	8	M16 5/8"	18	158	50	16	122	3.6	2	12	3,26	2,01
	114,3	220	135	18	180	8	M16 5/8"	18	158	50	16	128	3.6	2	12	-	-
125	133	250	152	18	210	8	M16 5/8"	18	188	50	18	148	4	3	12	4,07	2,86
	139,7	250	158	18	210	8	M16 5/8"	18	188	50	18	154	4	3	12	-	-
150	159	285	178	18	240	8	M20 3/4"	22	212	50	18	172	4.5	3	12	5,05	3,26
	168,3	285	188	18	240	8	M20 3/4"	22	212	50	18	181	4.5	3	12	-	-
200	216	340	235	20	295	8	M20 3/4"	22	268	55	20	230	5.9	3	16	6,7	5,13
	219,1	340	238	20	295	8	M20 3/4"	22	268	60	20	233	5.9	3	16	-	-
250	267	395	288	22	350	12	M20 3/4"	22	320	60	22	282	6.3	3	16	9,09	7,18
	273	395	294	22	350	12	M20 3/4"	22	320	60	22	288	6.3	3	16	-	-

Dimensions in millimeter (mm).

DIN 2673 Loose Flange And Ring With Neck For Welding PN10

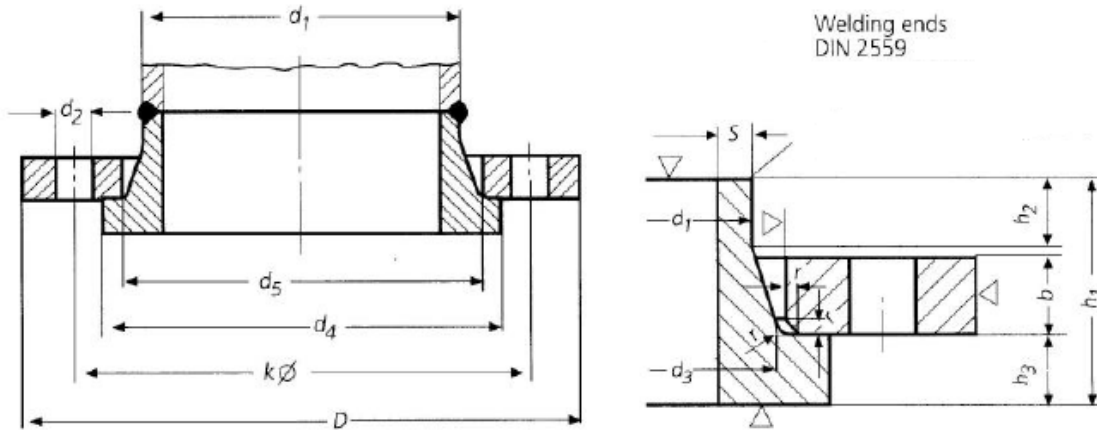

DN	d1	D	d5	b	k	No. of holes	Thread		d2	d4	h1	h3	d3	S	r	h2	KG Flange	KG Ring
300	318	445	338	26	400	12	M20	3/4"	22	370	60	22	332	7.1	3	16	12,5	8,5
	323.9	445	344	26	400	12	M20	3/4"	22	370	60	22	338	7.1	3	16	-	-
350	355,6	505	376	28	460	16	M20	3/4"	22	430	60	22	370	7.1	4	16	16,6	10,9
	368	505	388	28	460	16	M20	3/4"	22	430	60	22	382	7.1	4	16	-	-
400	406,4	565	430	32	515	16	M24	7/8"	26	482	65	24	426	7.1	4	16	22,4	14,2
	419	565	442	32	515	16	M24	7/8"	26	482	65	24	438	7.1	4	16	-	-
450	457	615	490	34	565	20	M24	7/8"	26	532	70	26	485	7.1	4	16	28,1	16,3
500	508	670	533	38	620	20	M24	7/8"	26	585	70	26	528	7.1	4	16	-	-
	521	670	545	38	620	20	M24	7/8"	26	585	70	26	540	7.1	4	16	32,5	19,4
600	609,6	780	633	44	725	20	M27	1"	30	685	80	26	628	7.1	4	18	-	-
	622	780	645	44	725	20	M27	1"	30	685	80	26	640	7.1	4	18	47,2	24,1
700	711,2	895	740	50	840	24	M27	1"	30	800	85	28	735	8	5	18	-	-
	720	895	748	50	840	24	M27	1"	30	800	85	28	742	8	5	18	67,6	34,4
800	812.8	1015	843	56	950	24	M30	1-1/8"	33	905	90	30	838	8	5	18	-	-
	820	1015	850	56	950	24	M30	1-1/8"	33	905	90	30	845	8	5	18	97	44,1
900	914,4	1115	947	62	1050	28	M30	1-1/8"	33	1005	95	32	940	10	5	20	-	-
	920	1115	952	62	1050	28	M30	1-1/8"	33	1005	95	32	945	10	5	20	117	54,1
1000	1016	1230	1050	68	1160	28	M33	1-1/4"	36	1110	100	34	1044	10	5	20	-	-
	1020	1230	1055	68	1160	28	M33	1-1/4"	36	1110	100	34	1048	10	5	20	152	69,2
1200	1220	1455	1260	80	1380	32	M36	1-3/8"	39	1330	110	38	1250	11	5	25	235	111

Dimensions in millimeter (mm).

DIN 28115 Long Neck Welding Flange PN10 and PN25

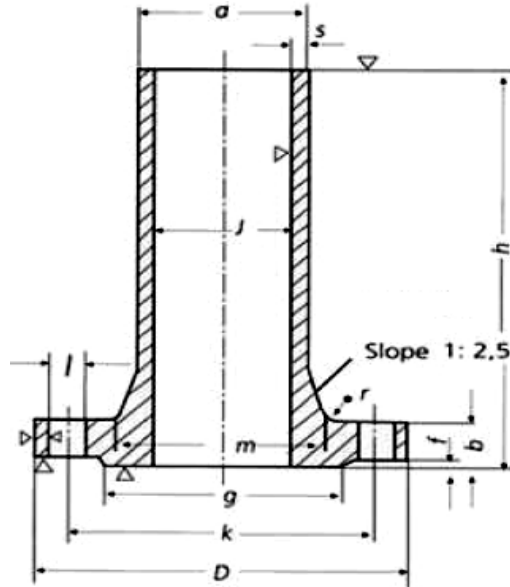

PN10																	
DN	Service Pressure		a	s	D	j	b	h	m	r	g	f	k	No. of holes	l	Thread	KG
25	8 Kg/cm ² 200 °C		38	7	115	24	16	120	50	8	68	2	85	4	14	M12(1/2")	1,7
32			51	8	140	35	16	120	62	8	78	2	100	4	18	M16(5/8")	2,8
40			57	8	150	41	16	120	70	8	88	3	110	4	18	M16(5/8")	3,2
50			70	8	165	54	18	120	85	8	102	3	125	4	18	M16(5/8")	4,2
65			89	8	185	73	18	170	104	8	122	3	145	4	18	M16(5/8")	6,8
80			102	8	200	86	20	170	118	8	138	3	160	4	18	M16(5/8")	7,8
100			121	10	220	101	20	170	138	8	158	3	180	8	18	M16(5/8")	9,7
125			146	10	250	126	22	170	164	10	188	3	210	8	18	M16(5/8")	11,6
150			171	10	285	151	22	170	188	10	212	3	240	8	23	M20(3/4")	14
200			224	10	340	204	22	170	246	10	268	3	295	8	23	M20(3/4")	20,4

PN25																				
DN	Nominal Pressure Kg/cm ²				Service Pressure to 200°C	a	s	D	j	b	h	m	r	g	f	k	No. of holes	l	Thread	KG
25	16	25	40	32	38	7	115	24	18	120	50	8	68	2	85	4	14	M12(1/2")	1.9	
32	16	25	40	32	51	8	140	35	18	120	62	8	78	2	100	4	18	M16(5/8")	3.0	
40	16	25	40	32	57	8	150	41	18	120	70	8	88	3	110	4	18	M16(5/8")	3.2	
50	16	25	40	32	70	8	165	54	20	120	85	8	102	3	125	4	18	M16(5/8")	4.5	
65	16	.	.	13	89	8	185	73	22	170	104	8	122	3	145	4	18	M16(5/8")	7.5	
	.	25	40	32	89	8	185	73	22	170	104	8	122	3	145	8	18	M16(5/8")	7.3	
80	16	.	.	13	102	8	200	86	24	170	118	8	138	3	160	8	18	M16(5/8")	8.4	
	.	25	40	32	102	8	200	86	24	170	118	8	138	3	160	8	18	M16(5/8")	8.4	
100	16	.	.	13	121	10	220	101	24	170	138	8	158	3	180	8	18	M16(5/8")	9.8	
125	16	.	.	13	146	10	250	126	26	170	164	10	188	3	210	8	18	M16(5/8")	12.6	
150	16	.	.	13	171	10	285	151	28	170	188	10	212	3	240	8	23	M20(3/4")	15.8	
200	16	.	.	13	224	10	340	204	34	170	246	10	268	3	295	12	23	M20(3/4")	24.2	

Dimensions in millimeter (mm).

DIN 86029 Hubbed Slip-on Flange For Welding PN10

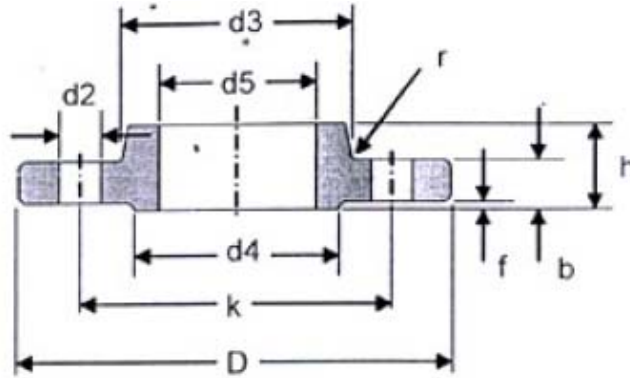

DN	Pipe OD	D	d5	b	k	h	d3	r	d4	f	No. of holes	d2	KG
10	17.2	90	17.7	14	60	20	30	4	40	2	4	14	0.56
15	21.3	95	22	14	65	20	35	4	45	2	4	14	0.62
20	26.9	105	27.6	16	75	24	45	4	58	2	4	14	0.91
25	33.7	115	34.4	16	85	24	52	5	68	2	4	14	1.09
32	42.4	140	43.1	16	100	26	60	5	78	2	4	18	1.58
40	48.3	150	49	16	110	26	70	5	88	3	4	18	1.76
50	60.3	165	61.1	18	125	28	85	5	102	3	4	18	2.39
65	76.1	185	77.1	18	145	32	105	5	122	3	4	18	3.1
80	88.9	200	90.3	20	160	34	118	5	138	3	8	18	3.77
100	114.3	220	115.9	20	180	38	140	5	158	3	8	18	4.29
125	139.7	250	141.6	22	210	40	168	5	188	3	8	18	5.86
150	168.3	285	170.5	22	240	44	196	5	212	3	8	22	7.22
175	193.7	315	196.1	24	270	44	224	6	242	3	8	22	9.18
200	219.4	340	222	24	295	44	247	6	268	3	8	22	9.95
250	273	395	276	26	350	46	300	6	320	3	12	22	12.69
300	323.9	445	327	26	400	46	352	6	370	4	12	22	14.4
350	355.6	505	359	26	460	53	398	10	430	4	16	22	22.36
400	406.4	565	410	26	515	57	448	10	482	4	16	26	26.85
450	457	615	461	28	565	62	502	10	532	4	20	26	32.53
500	508	670	512	28	620	67	552	10	585	4	20	26	37.84
600	610	780	614	28	725	75	658	10	685	5	20	30	49.32
700	711	895	716	30	840	77	760	10	800	5	24	30	63.86
800	813	1015	818	32	950	84	864	10	905	5	24	33	85.19
900	914	1115	920	34	1050	88	969	10	1005	5	28	33	101.36
1000	1016	1230	1022	34	1160	92	1071	10	1110	5	28	36	119.72

Dimensions in millimeter (mm).

DIN 86030 Hubbed Slip-on Flange For Welding PN16

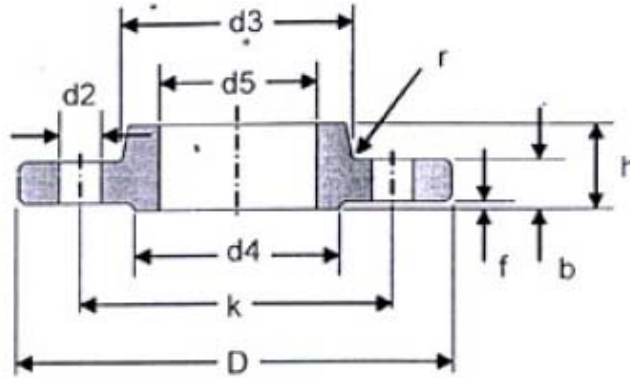

DN	Pipe OD	D	d5	b	k	h	d3	r	d4	f	No. of holes	d2	KG
10	17.2	90	17.7	14	60	20	30	4	40	2	4	14	0.56
15	21.3	95	22	14	65	20	35	4	45	2	4	14	0.62
20	26.9	105	27.6	16	75	24	45	4	58	2	4	14	0.91
25	33.7	115	34.4	16	85	24	52	5	68	2	4	14	1.09
32	42.4	140	43.1	16	100	26	60	5	78	2	4	18	1.58
40	48.3	150	49	16	110	26	70	5	88	3	4	18	1.76
50	60.3	165	61.1	18	125	28	85	5	102	3	4	18	2.39
65	76.1	185	77.1	18	145	32	105	5	122	3	4	18	3.1
80	88.9	200	90.3	20	160	34	118	5	138	3	8	18	3.77
100	114.3	220	115.9	20	180	38	140	5	158	3	8	18	4.29
125	139.7	250	141.6	22	210	40	168	5	188	3	8	18	5.86
150	168.3	285	170.5	22	240	44	196	5	212	3	8	22	7.22
175	193.7	315	196.1	24	270	44	224	6	242	3	8	22	9.18
200	219.4	340	222	24	295	44	247	6	268	3	12	22	9.7
250	273	405	276	26	355	46	300	6	320	3	12	26	13.5
300	323.9	460	327	28	410	46	355	6	378	4	12	26	17.29
350	355.6	520	359	30	470	57	400	10	438	4	16	26	27.68
400	406.4	580	410	32	525	63	457	10	490	4	16	30	36.13
450	457	640	461	34	585	68	505	10	550	4	20	30	44.25
500	508	715	512	34	650	73	559	10	610	4	20	33	56.88
600	610	840	614	36	770	83	664	10	725	5	20	36	80.95
700	711	910	716	36	840	83	760	10	795	5	24	36	76.84
800	813	1025	818	38	950	90	864	10	900	5	24	39	99.34
900	914	1125	920	40	1050	94	969	10	1000	5	28	39	116.63
1000	1016	1255	1022	42	1170	100	1073	10	1115	5	28	42	154.09

Dimensions in millimeter (mm).

Tel: +919867815181

Email: sales@randhirmetal.com

Website: www.randhirmetal.com